

STK600 User Guide

[1: Introduction](#)

- [1.1: Overview](#)
- [1.2: Features](#)
- [1.3: What's New](#)
- [1.4: Known Issues](#)
- [1.5: Device Support](#)

[2: Getting Started](#)

- [2.1: Kit Contents](#)
- [2.2: Quick Start](#)
- [2.3: Connecting the Hardware](#)
- [2.4: Example Application: Using LEDs and Switches](#)

[3: Target Socket System](#)

- [3.1: Socket System](#)
- [3.2: Socket Card and Routing Card](#)
- [3.3: Selecting the correct routing and socket cards](#)
- [3.4: Mounting the cards](#)
- [3.5: Signal integrity](#)

[4: Hardware Description](#)

- [4.1: STK600 Block Diagram](#)
- [4.2: Target Voltage VTG](#)
- [4.3: Analog Reference Voltages](#)
- [4.4: RESET Control](#)
- [4.5: Port Connectors](#)
- [4.6: AVR32 Pin Mapping](#)
- [4.7: LEDs and Switches](#)
- [4.8: Clock Settings](#)
- [4.9: User RS232 Interface](#)
- [4.10: DataFlash Non-Volatile Memory](#)
- [4.11: Expansion Connectors](#)
- [4.12: User USB connector](#)
- [4.13: CAN transceiver](#)
- [4.14: LIN transceiver](#)
- [4.15: Miscellaneous](#)

[5: Programming](#)

- [5.1: ISP Programming](#)
- [5.2: Parallel High Voltage Programming](#)
- [5.3: Serial High Voltage Programming](#)
- [5.4: JTAG Programming](#)
- [5.5: PDI Programming](#)
- [5.6: TPI Programming](#)
- [5.7: In-System Programming of an External Target System](#)

[6: Troubleshooting and Support](#)

- [6.1: Troubleshooting Guide](#)
- [6.2: Technical Support](#)
- [6.3: Manual Firmware Upgrade](#)

1. Introduction

1.1 Overview

Congratulation with your STK600 AVR® Flash MCU Starter Kit. The STK600 is a complete starter kit and development system for the AVR and AVR®32 flash microcontrollers from ATMEL® Corporation. It is designed to give designers a quick start to develop code on the AVR, combined with advanced features for using the starter kit to prototype and test new designs.

New firmware releases for STK600 are embedded with the releases of AVR Studio®. The upgrade process will start when you connect to the STK600 board (you will be asked to perform the procedure). If for some reason the automatic upgrade fails, please try the manual upgrade procedure.



1.2 Features

- AVR Studio 4/AVR32 Studio compatible
- USB Interface to PC for programming and control
- Powered from USB bus or from an external 10-15V DC power supply
- Serial In-System Programming (ISP) of AVR devices
- JTAG programming of AVR and AVR32 devices
- ISP and JTAG programming of AVR devices in external target systems
- Flexible routing and socket card system for easy mounting of all supported devices
- 8 push-buttons for general use
- 8 LEDs for general use
- All AVR I/O ports easily accessible through pin header connectors
- Expansion connectors for plug-in modules and prototyping area
- On-board 2Mbit Dataflash for non-volatile data
- USB mini-AB (On-The-Go) connector for USB devices
- PHY and DSUB-9 connector for RS232 interface
- PHY and DSUB-9 connector for CAN bus
- PHY and header for LIN bus
- Device board with an ATmega2560 AVR microcontroller is included.

Note

Socketcards and routingcards must be bought separately.

1.3 What's New

November 4th, 2008

STK600 firmware versions 02.06, 02.01, 02.00

Added programming support for ATtiny10.

October 2nd, 2008

STK600 firmware versions 02.05, 02.00, 02.00

Added programming support for ATxmega256A3, ATxmega128A3, ATxmega64A3, ATxmega256A3B, ATmega32U6, ATmega88PA, ATmega168PA, ATmega324PA and ATmega32HVB

July 15th, 2008

STK600 firmware versions 02.05, 02.00, 02.00

Added full programming support for ATmega16U4, ATtiny13A, ATmega8A, ATmega16A, ATmega32A, ATmega64A, ATmega128A

April 8th, 2008

STK600 firmware versions 02.05, 02.00, 02.00

March 27th, 2008

STK600 firmware versions 02.04, 02.00, 02.00

1.4 Known Issues

There are at the moment no known issues with the STK600.

1.5 Device Support

AVR Studio and AVR32 Studio has support for a range of devices in all speed grades. Support for new AVR devices may be added in new versions of the software. Latest versions of AVR Studio and AVR32 Studio are always available from www.atmel.com.

Table 1.1. AVR Studio device support

Device	Routing card	Socket card	Programming modes	Comment
ATtiny4		STK600-ATTINY10	TPI	
ATtiny5		STK600-ATTINY10	TPI	
ATtiny9		STK600-ATTINY10	TPI	
ATtiny10		STK600-ATTINY10	TPI	
ATtiny11	STK600-RC008T-2	STK600-DIP	HVSP	
ATtiny12	STK600-RC008T-2	STK600-DIP	HVSP, ISP	
ATtiny13	STK600-RC008T-2	STK600-DIP	HVSP, ISP	
ATtiny13A	STK600-RC008T-2	STK600-DIP	HVSP, ISP	
ATtiny15	STK600-RC008T-7	STK600-DIP	HVSP, ISP	
ATtiny2313	STK600-RC020T-1	STK600-DIP	HVPP, ISP	
ATtiny2313A	STK600-RC020T-1	STK600-DIP	HVPP, ISP	
ATtiny4313	STK600-RC020T-1	STK600-DIP	HVPP, ISP	
ATtiny43U		STK600-TinyX3U	HVPP, ISP	
ATtiny24	STK600-RC014T-12	STK600-DIP	HVSP, ISP	
ATtiny44	STK600-RC014T-12	STK600-DIP	HVSP, ISP	
ATtiny84	STK600-RC014T-12	STK600-DIP	HVSP, ISP	
ATtiny24A	STK600-RC014T-12	STK600-DIP	HVSP, ISP	
ATtiny44A	STK600-RC014T-12	STK600-DIP	HVSP, ISP	
ATtiny25	STK600-RC008T-2	STK600-DIP	HVSP, ISP	
ATtiny45	STK600-RC008T-2	STK600-DIP	HVSP, ISP	
ATtiny85	STK600-RC008T-2	STK600-DIP	HVSP, ISP	
ATtiny26	STK600-RC020T-8	STK600-DIP	HVPP, ISP	
ATtiny261	STK600-RC020T-8	STK600-DIP	HVPP, ISP	
ATtiny261A	STK600-RC020T-8	STK600-DIP	HVPP, ISP	
ATtiny461	STK600-RC020T-8	STK600-DIP	HVPP, ISP	
ATtiny861	STK600-RC020T-8	STK600-DIP	HVPP, ISP	
ATtiny861A	STK600-RC020T-8	STK600-DIP	HVPP, ISP	
ATtiny261	STK600-RC020T-43	STK600-SOIC	HVPP, ISP	
ATtiny261A	STK600-RC020T-43	STK600-SOIC	HVPP, ISP	

ATtiny461	STK600-RC020T-43	STK600-SOIC	HVPP, ISP	
ATtiny461A	STK600-RC020T-43	STK600-SOIC	HVPP, ISP	
ATtiny861	STK600-RC020T-43	STK600-SOIC	HVPP, ISP	
ATtiny861A	STK600-RC020T-43	STK600-SOIC	HVPP, ISP	
ATtiny87	STK600-RC020T-23	STK600-SOIC	HVPP, ISP	
ATtiny167	STK600-RC020T-23	STK600-SOIC	HVPP, ISP	
ATtiny28	STK600-RC028T-3	STK600-DIP	HVPP	
ATtiny48	STK600-RC028M-6	STK600-DIP	HVPP, ISP	
ATtiny88	STK600-RC028M-6	STK600-DIP	HVPP, ISP	
ATtiny88		QT600-ATTINY88-QT8	ISP	
ATmega8515	STK600-RC040M-4	STK600-DIP	HVPP, ISP	
ATmega8515	STK600-RC044M-30	STK600-TQFP44	HVPP, ISP	
ATmega8535	STK600-RC040M-5	STK600-DIP	HVPP, ISP	
ATmega8535	STK600-RC044M-31	STK600-TQFP44	HVPP, ISP	
ATmega162	STK600-RC040M-4	STK600-DIP	HVPP, ISP, JTAG	
ATmega162	STK600-RC044M-30	STK600-TQFP44	HVPP, ISP, JTAG	
ATmega16	STK600-RC040M-5	STK600-DIP	HVPP, ISP, JTAG	
ATmega16A	STK600-RC040M-5	STK600-DIP	HVPP, ISP, JTAG	
ATmega32	STK600-RC040M-5	STK600-DIP	HVPP, ISP, JTAG	
ATmega32A	STK600-RC040M-5	STK600-DIP	HVPP, ISP, JTAG	
ATmega164P	STK600-RC040M-5	STK600-DIP	HVPP, ISP, JTAG	
ATmega164PA	STK600-RC040M-5	STK600-DIP	HVPP, ISP, JTAG	
ATmega324P	STK600-RC040M-5	STK600-DIP	HVPP, ISP, JTAG	
ATmega324PA	STK600-RC040M-5	STK600-DIP	HVPP, ISP, JTAG	
ATmega324PA		QT600-ATMEGA324-QM64	JTAG	
ATmega644	STK600-RC040M-5	STK600-DIP	HVPP, ISP, JTAG	
ATmega644P	STK600-RC040M-5	STK600-DIP	HVPP, ISP, JTAG	
ATmega644PA	STK600-RC040M-5	STK600-DIP	HVPP, ISP, JTAG	
ATmega1284P	STK600-RC040M-5	STK600-DIP	HVPP, ISP, JTAG	
ATmega16	STK600-RC044M-31	STK600-TQFP44	HVPP, ISP, JTAG	
ATmega16A	STK600-RC044M-31	STK600-TQFP44	HVPP, ISP, JTAG	
ATmega32	STK600-RC044M-31	STK600-TQFP44	HVPP, ISP, JTAG	
ATmega32A	STK600-RC044M-31	STK600-TQFP44	HVPP, ISP, JTAG	
ATmega164P	STK600-RC044M-31	STK600-TQFP44	HVPP, ISP, JTAG	
ATmega164PA	STK600-RC044M-31	STK600-TQFP44	HVPP, ISP, JTAG	
ATmega324P	STK600-RC044M-31	STK600-TQFP44	HVPP, ISP, JTAG	
ATmega324PA	STK600-RC044M-31	STK600-TQFP44	HVPP, ISP, JTAG	
ATmega644	STK600-RC044M-31	STK600-TQFP44	HVPP, ISP, JTAG	
ATmega644P	STK600-RC044M-31	STK600-TQFP44	HVPP, ISP, JTAG	
ATmega644PA	STK600-RC044M-31	STK600-TQFP44	HVPP, ISP, JTAG	
ATmega1284P	STK600-RC044M-31	STK600-TQFP44	HVPP, ISP, JTAG	
ATmega8	STK600-RC028M-6	STK600-DIP	HVPP, ISP	
ATmega8A	STK600-RC028M-6	STK600-DIP	HVPP, ISP	
ATmega48	STK600-RC028M-6	STK600-DIP	HVPP, ISP	
ATmega88	STK600-RC028M-6	STK600-DIP	HVPP, ISP	
ATmega168	STK600-RC028M-6	STK600-DIP	HVPP, ISP	
ATmega48P	STK600-RC028M-6	STK600-DIP	HVPP, ISP	
ATmega48PA	STK600-RC028M-6	STK600-DIP	HVPP, ISP	
ATmega88P	STK600-RC028M-6	STK600-DIP	HVPP, ISP	
ATmega88PA	STK600-RC028M-6	STK600-DIP	HVPP, ISP	
ATmega168P	STK600-RC028M-6	STK600-DIP	HVPP, ISP	
ATmega168PA	STK600-RC028M-6	STK600-DIP	HVPP, ISP	
ATmega328P	STK600-RC028M-6	STK600-DIP	HVPP, ISP, JTAG	
ATmega8	STK600-RC032M-29	STK600-TQFP32	HVPP, ISP	

ATmega8A	STK600-RC032M-29	STK600-TQFP32	HVPP, ISP	
ATmega48	STK600-RC032M-29	STK600-TQFP32	HVPP, ISP	
ATmega88	STK600-RC032M-29	STK600-TQFP32	HVPP, ISP	
ATmega168	STK600-RC032M-29	STK600-TQFP32	HVPP, ISP	
ATmega48P	STK600-RC032M-29	STK600-TQFP32	HVPP, ISP	
ATmega48PA	STK600-RC032M-29	STK600-TQFP32	HVPP, ISP	
ATmega88P	STK600-RC032M-29	STK600-TQFP32	HVPP, ISP	
ATmega88PA	STK600-RC032M-29	STK600-TQFP32	HVPP, ISP	
ATmega168P	STK600-RC032M-29	STK600-TQFP32	HVPP, ISP	
ATmega168PA	STK600-RC032M-29	STK600-TQFP32	HVPP, ISP	
ATmega328P	STK600-RC032M-29	STK600-TQFP32	HVPP, ISP, JTAG	
ATmega64	STK600-RC064M-9	STK600-TQFP64	HVPP, ISP, JTAG	
ATmega64A	STK600-RC064M-9	STK600-TQFP64	HVPP, ISP, JTAG	
ATmega128	STK600-RC064M-9	STK600-TQFP64	HVPP, ISP, JTAG	
ATmega128A	STK600-RC064M-9	STK600-TQFP64	HVPP, ISP, JTAG	
ATmega1281	STK600-RC064M-9	STK600-TQFP64	HVPP, ISP, JTAG	
ATmega2561	STK600-RC064M-9	STK600-TQFP64	HVPP, ISP, JTAG	
ATmega165	STK600-RC064M-10	STK600-TQFP64	HVPP, ISP, JTAG	
ATmega165P	STK600-RC064M-10	STK600-TQFP64	HVPP, ISP, JTAG	
ATmega169	STK600-RC064M-10	STK600-TQFP64	HVPP, ISP, JTAG	
ATmega169P	STK600-RC064M-10	STK600-TQFP64	HVPP, ISP, JTAG	
ATmega169PA	STK600-RC064M-10	STK600-TQFP64	HVPP, ISP, JTAG	
ATmega325	STK600-RC064M-10	STK600-TQFP64	HVPP, ISP, JTAG	
ATmega325P	STK600-RC064M-10	STK600-TQFP64	HVPP, ISP, JTAG	
ATmega329	STK600-RC064M-10	STK600-TQFP64	HVPP, ISP, JTAG	
ATmega329P	STK600-RC064M-10	STK600-TQFP64	HVPP, ISP, JTAG	
ATmega645	STK600-RC064M-10	STK600-TQFP64	HVPP, ISP, JTAG	
ATmega649	STK600-RC064M-10	STK600-TQFP64	HVPP, ISP, JTAG	
ATmega649P	STK600-RC064M-10	STK600-TQFP64	HVPP, ISP, JTAG	
ATmega640	STK600-RC100M-11	STK600-TQFP100	HVPP, ISP, JTAG	
ATmega1280	STK600-RC100M-11	STK600-TQFP100	HVPP, ISP, JTAG	
ATmega2560	STK600-RC100M-11	STK600-TQFP100	HVPP, ISP, JTAG	
ATmega2560		STK600-ATMEGA2560	HVPP, ISP, JTAG	
ATmega3250	STK600-RC100M-18	STK600-TQFP100	HVPP, ISP, JTAG	
ATmega3250P	STK600-RC100M-18	STK600-TQFP100	HVPP, ISP, JTAG	
ATmega3290	STK600-RC100M-18	STK600-TQFP100	HVPP, ISP, JTAG	
ATmega3290P	STK600-RC100M-18	STK600-TQFP100	HVPP, ISP, JTAG	
ATmega6450	STK600-RC100M-18	STK600-TQFP100	HVPP, ISP, JTAG	
ATmega6490	STK600-RC100M-18	STK600-TQFP100	HVPP, ISP, JTAG	
AT90USB82	STK600-RC032U-20	STK600-TQFP32	HVPP, ISP	
AT90USB162	STK600-RC032U-20	STK600-TQFP32	HVPP, ISP	
ATmega8U2	STK600-RC032U-20	STK600-TQFP32	HVPP, ISP	
ATmega16U2	STK600-RC032U-20	STK600-TQFP32	HVPP, ISP	
ATmega32U2	STK600-RC032U-20	STK600-TQFP32	HVPP, ISP	
ATmega16U4	STK600-RC044U-25	STK600-TQFP44	HVPP, ISP, JTAG	
ATmega32U4	STK600-RC044U-25	STK600-TQFP44	HVPP, ISP, JTAG	
ATmega32U6	STK600-RC064U-17	STK600-TQFP64	HVPP, ISP, JTAG	
AT90USB646	STK600-RC064U-17	STK600-TQFP64	HVPP, ISP, JTAG	
AT90USB1286	STK600-RC064U-17	STK600-TQFP64	HVPP, ISP, JTAG	
AT90USB647	STK600-RC064U-17	STK600-TQFP64	HVPP, ISP, JTAG	
AT90USB1287	STK600-RC064U-17	STK600-TQFP64	HVPP, ISP, JTAG	
AT90CAN32	STK600-RC064M-9	STK600-TQFP64	HVPP, ISP, JTAG	
AT90CAN64	STK600-RC064M-9	STK600-TQFP64	HVPP, ISP, JTAG	

AT90CAN128	STK600-RC064M-9	STK600-TQFP64	HVPP, ISP, JTAG	
ATmega32C1	STK600-RCPWM-22	STK600-TQFP32	HVPP, ISP	
ATmega64C1	STK600-RCPWM-22	STK600-TQFP32	HVPP, ISP	
AT90PWM2	STK600-RCPWM-19	STK600-SOIC	HVPP, ISP	
AT90PWM3	STK600-RCPWM-19	STK600-SOIC	HVPP, ISP	
AT90PWM2B	STK600-RCPWM-19	STK600-SOIC	HVPP, ISP	
AT90PWM3B	STK600-RCPWM-19	STK600-SOIC	HVPP, ISP	
AT90PWM216	STK600-RCPWM-19	STK600-SOIC	HVPP, ISP	
AT90PWM316	STK600-RCPWM-19	STK600-SOIC	HVPP, ISP	
ATmega16M1	STK600-RCPWM-22	STK600-TQFP32	HVPP, ISP	
ATmega32M1	STK600-RCPWM-22	STK600-TQFP32	HVPP, ISP	
ATmega64M1	STK600-RCPWM-22	STK600-TQFP32	HVPP, ISP	
ATmega16HVB	STK600-RC044M-24	STK600-TSSOP44	HVPP, ISP	
ATmega32HVB	STK600-RC044M-24	STK600-TSSOP44	HVPP, ISP	
ATmega128RFA1		STK600-ATMEGA128RFA1	JTAG	
ATxmega64A1	STK600-RC100X-13	STK600-TQFP100	JTAG, PDI	
ATxmega128A1	STK600-RC100X-13	STK600-TQFP100	JTAG, PDI	
ATxmega128A1_revD	STK600-RC100X-13	STK600-TQFP100	JTAG, PDI	
ATxmega128A1U	STK600-RC100X-13	STK600-TQFP100	JTAG, PDI	
ATxmega128A1		STK600-ATXMEGA128A1	JTAG, PDI	
ATxmega128A1		QT600-ATXMEGA128A1-QT16	JTAG, PDI	
ATxmega64A3	STK600-RC064X-14	STK600-TQFP64	JTAG, PDI	
ATxmega128A3	STK600-RC064X-14	STK600-TQFP64	JTAG, PDI	
ATxmega256A3	STK600-RC064X-14	STK600-TQFP64	JTAG, PDI	
ATxmega256A3B	STK600-RC064X-14	STK600-MLF64	JTAG, PDI	
ATxmega64D3	STK600-RC064X-14	STK600-TQFP64	PDI	
ATxmega128D3	STK600-RC064X-14	STK600-TQFP64	PDI	
ATxmega192D3	STK600-RC064X-14	STK600-TQFP64	PDI	
ATxmega256D3	STK600-RC064X-14	STK600-TQFP64	PDI	
ATxmega32A4	STK600-RC044X-15	STK600-TQFP44	JTAG, PDI	
ATxmega16A4	STK600-RC044X-15	STK600-TQFP44	JTAG, PDI	
ATxmega16D4	STK600-RC044X-15	STK600-TQFP44	PDI	
ATxmega32D4	STK600-RC044X-15	STK600-TQFP44	PDI	

Table 1.2. AVR32 Studio device support

Device	Routing card	Socket card	Programming modes	Comment
AT32UC3A0512		STK600-uC3-144	JTAG	
AT32UC3A0256		STK600-uC3-144	JTAG	
AT32UC3A0128		STK600-uC3-144	JTAG	
AT32UC3A0512	STK600-RCUC3A144-33	STK600-TQFP144	JTAG	
AT32UC3A0256	STK600-RCUC3A144-33	STK600-TQFP144	JTAG	
AT32UC3A0128	STK600-RCUC3A144-33	STK600-TQFP144	JTAG	
AT32UC3A1512	STK600-RCu3A100-28	STK600-TQFP100	JTAG	
AT32UC3A1256	STK600-RCu3A100-28	STK600-TQFP100	JTAG	
AT32UC3A1128	STK600-RCu3A100-28	STK600-TQFP100	JTAG	
AT32UC3B0256	STK600-RCu3B0-21	STK600-TQFP64-2	JTAG	
AT32UC3B0512RevC	STK600-RCu3B0-21	STK600-TQFP64-2	JTAG	
AT32UC3B0512	STK600-RCu3B0-21	STK600-TQFP64-2	JTAG	
AT32UC3B0128	STK600-RCu3B0-21	STK600-TQFP64-2	JTAG	
AT32UC3B064	STK600-RCu3B0-21	STK600-TQFP64-2	JTAG	
AT32UC3B1256	STK600-RCu3B48-27	STK600-TQFP48	JTAG	
AT32UC3B164	STK600-RCu3B48-27	STK600-TQFP48	JTAG	
AT32UC3C0512	STK600-RCUC3C0-36	STK600-TQFP144	JTAG	
AT32UC3C0256	STK600-RCUC3C0-36	STK600-TQFP144	JTAG	

AT32UC3C0128	STK600-RCUC3C0-36	STK600-TQFP144	JTAG	
AT32UC3C064	STK600-RCUC3C0-36	STK600-TQFP144	JTAG	
AT32UC3C1512	STK600-RCUC3C1-38	STK600-TQFP100	JTAG	
AT32UC3C1256	STK600-RCUC3C1-38	STK600-TQFP100	JTAG	
AT32UC3C1128	STK600-RCUC3C1-38	STK600-TQFP100	JTAG	
AT32UC3C164	STK600-RCUC3C1-38	STK600-TQFP100	JTAG	
AT32UC3C2512	STK600-RCUC3C2-40	STK600-TQFP64-2	JTAG	
AT32UC3C2256	STK600-RCUC3C2-40	STK600-TQFP64-2	JTAG	
AT32UC3C2128	STK600-RCUC3C2-40	STK600-TQFP64-2	JTAG	
AT32UC3C264	STK600-RCUC3C2-40	STK600-TQFP64-2	JTAG	
AT32UC3C0512	STK600-RCUC3C0-37	STK600-TQFP144	JTAG	
AT32UC3C0256	STK600-RCUC3C0-37	STK600-TQFP144	JTAG	
AT32UC3C0128	STK600-RCUC3C0-37	STK600-TQFP144	JTAG	
AT32UC3C064	STK600-RCUC3C0-37	STK600-TQFP144	JTAG	
AT32UC3C1512	STK600-RCUC3C1-39	STK600-TQFP100	JTAG	
AT32UC3C1256	STK600-RCUC3C1-39	STK600-TQFP100	JTAG	
AT32UC3C1128	STK600-RCUC3C1-39	STK600-TQFP100	JTAG	
AT32UC3C164	STK600-RCUC3C1-39	STK600-TQFP100	JTAG	
AT32UC3C2512	STK600-RCUC3C2-41	STK600-TQFP64-2	JTAG	
AT32UC3C2256	STK600-RCUC3C2-41	STK600-TQFP64-2	JTAG	
AT32UC3C2128	STK600-RCUC3C2-41	STK600-TQFP64-2	JTAG	
AT32UC3C264	STK600-RCUC3C2-41	STK600-TQFP64-2	JTAG	
AT32UC3L064	STK600-RCUC3L0-34	STK600-TQFP48	JTAG	
AT32UC3L032	STK600-RCUC3L0-34	STK600-TQFP48	JTAG	
AT32UC3L016	STK600-RCUC3L0-34	STK600-TQFP48	JTAG	
AT32UC3L064		QT600-AT32UC3L-QM64	JTAG	
AT32UC3D1128	STK600-RCu3B0-21	STK600-TQFP64-2	JTAG	

2. Getting Started

2.1 Kit Contents

The box contains:

- STK600 starter kit evaluation board
- Cables for STK600:
 - Two 10-wire cables for I/O ports and Parallel mode programming
 - One 6-wire cable for In-System Programming
 - Four 2-wire cable for UART and dataflash connections
- USB cable
- DC power cable
- Atmel CD-ROM with datasheets and software
- Device board with an ATmega2560 AVR device
- Two sets of screws and nuts, and one set of clips

2.2 Quick Start

The STK600 starter kit is shipped with a device board with a ATmega2560 AVR microcontroller.

The STK600 can source power to the microcontroller through the USB cable. Remember that the power available through the USB cable is limited. If your application attaches several peripherals to the STK600, you should use an external power source connected to the DC input socket on

STK600. The external power supply should be 9-15V DC with positive center connector.

The power switch turns the STK600 main power on and off. The red LED is lit when power is on, and the status LED will turn green. The green LED beside the VTG jumper indicates that the target voltage is present.

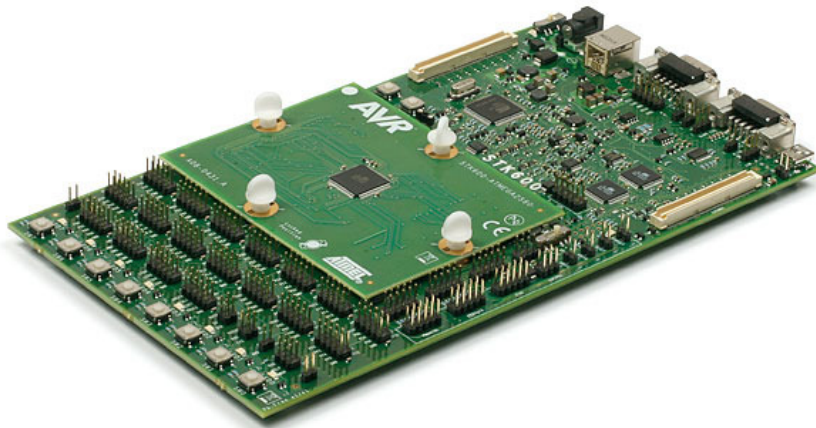

An example application is described in the [Example Application](#) section. To evaluate the example, copy the code into a new project in AVR Studio.

Build the project (menu: Build) and program the resulting hex file to the target (menu: Tools/Program AVR)

To program the code using ISP:

- Connect a 6 lead flat cable between the two headers marked "ISP"
- Adjust target voltage from the HW settings tab. Refer to the device datasheet for operating range. STK600 default voltage is 0V.
- Select ISP on the main tab and set ISP frequency to 200Khz or lower^[1]
- Program the application hex file from the program tab

To run the demo:

- Connect PORTB to LEDS using a 10 lead flat cable
- Connect PORTD to SWITCHES using a 10 lead flat cable
- Press one of the switches. The leds will display a blinking pattern, dependant of which switch is pressed

[1] The ATmega2560 has a default fuse setting that makes it run on a 1MHz internal clock. The maximum ISP frequency is 1/4 of the target clock frequency.

2.3 Connecting the Hardware

The STK600 must be connected to a host PC with a USB cable. Connect the cable to a free USB port on the PC or on a USB hub. The USB port must be capable of supplying 500mA. If using a USB hub, make sure it has an external power supply.

Connect the other end of the USB cable to the USB connector on STK600 sitting next to the DC jack.

Optionally, if STK600 is to be connected to external hardware that consumes more than 300mA, an external DC power supply can be connected to the DC jack on STK600. The cable supplied with the kit can be used. Connect the center pin to the positive voltage and the cap to ground.

See [Chapter 3, Target Socket System](#) on how to set up the routing card and socket card.

2.4 Example Application: Using LEDs and Switches

Copy the code from this document into AVR Studio.

Tip: You need to adjust the include file specified at the 2nd line if you want to run the demo application on a device different from the ATmega2560.

```

;***** STK600 LEDES and SWITCH demonstration
.include "m2560def.inc"
.def Temp =r16 ; Temporary register
.def Delay =r17 ; Delay variable 1
.def Delay2 =r18 ; Delay variable 2
;***** Initialization
RESET:
    ser        Temp
    out        DDRB,Temp                ; Set PORTB to output
;**** Test input/output
LOOP:
    out        PORTB,temp                ; Update LEDES
    sbis       PIND,0x00                 ; If (Port D, pin0 == 0)
    inc        Temp                       ; then count LEDES one down
    sbis       PIND,0x01                 ; If (Port D, pin1 == 0)
    dec        Temp                       ; then count LEDES one up
    sbis       PIND,0x02                 ; If (Port D, pin2 == 0)
    ror        Temp                       ; then rotate LEDES one right
    sbis       PIND,0x03                 ; If (Port D, pin3 == 0)
    rol        Temp                       ; then rotate LEDES one left
    sbis       PIND,0x04                 ; If (Port D, pin4 == 0)
    com        Temp                       ; then invert all LEDES
    sbis       PIND,0x05                 ; If (Port D, pin5 == 0)
    neg        Temp                       ; then invert all LEDES and add 1
    sbis       PIND,0x06                 ; If (Port D, pin6 == 0)
    swap       Temp                       ; then swap nibbles of LEDES
;**** Now wait a while to make LED changes visible.
DLY:
    dec        Delay
    brne      DLY
    dec        Delay2
    brne      DLY
    rjmp      LOOP                        ; Repeat loop forever

```

3. Target Socket System

3.1 Socket System

STK600 is designed to support all AVR devices (both AVR and AVR32) with internal flash memory. A system based on socket and routing cards is used to support different package types and pinouts on the STK600 board.

The picture below shows an STK600 with a mounted routing card and socket card.



3.2 Socket Card and Routing Card

A *socket card* is a general card that does not have any device specific hardware. E.g. a TQFP-64 socket card can be used for all devices that comes in a TQFP-64 package, regardless of pinout.



A routing card is a device specific card. It routes signals between the STK600 motherboard and the socket card. Note that several devices may use the same routing card if they share the same pinout.



A set of spring loaded connectors make the connection between the motherboard, routing card and socket card. Clips or screws hold the stack of cards together.



In addition to the socket and routing cards included in the kit, there are several add-on packs available to expand the part support for the STK600. See the [Device Support](#) page to get an overview over the different socket and routing cards.

3.3 Selecting the correct routing and socket cards

Selecting the correct routing and socket card can be done by looking at the [Device Support](#) table.

Correct routing and socket card can also be found by just selecting the correct device in the STK600 programming dialog in AVR Studio. A notification will display the correct routing and socket card to use, unless the STK600 already has the correct cards mounted. More information on the programming dialog can be found in the *Programming Dialog* pages in the AVR Studio help.

Note that some of the devices has a part specific socket card, i.e. a routing card that has a socket. In this case there is only one card to install onto the motherboard.

3.4 Mounting the cards

Mounting the routing and socket cards can either be done by plastic clips or plastic screw/nuts. Both sets are included in the STK600 package. Install either the clips or the nuts to the motherboard depending on what solution you want to use.

3.4.1 Using clips

Motherboard

The clips should be installed from the bottom side of the STK600 motherboard. When properly installed, two plastic locking springs holds the clip in place.



Routing card

Align the clips with the white lines on the motherboard. The routing card could now be placed above the four clips. Make sure that the routing card has the correct orientation, i.e. the text should face upwards, and the white dot in the corner should match the one on the STK600. Press down the routing card (i.e. compress the spring loaded connector on the STK600) and turn the clip 45 degrees in the clockwise direction so that it aligns with the white line on the routing card. It is easiest to do two opposite clips before locking the two last.

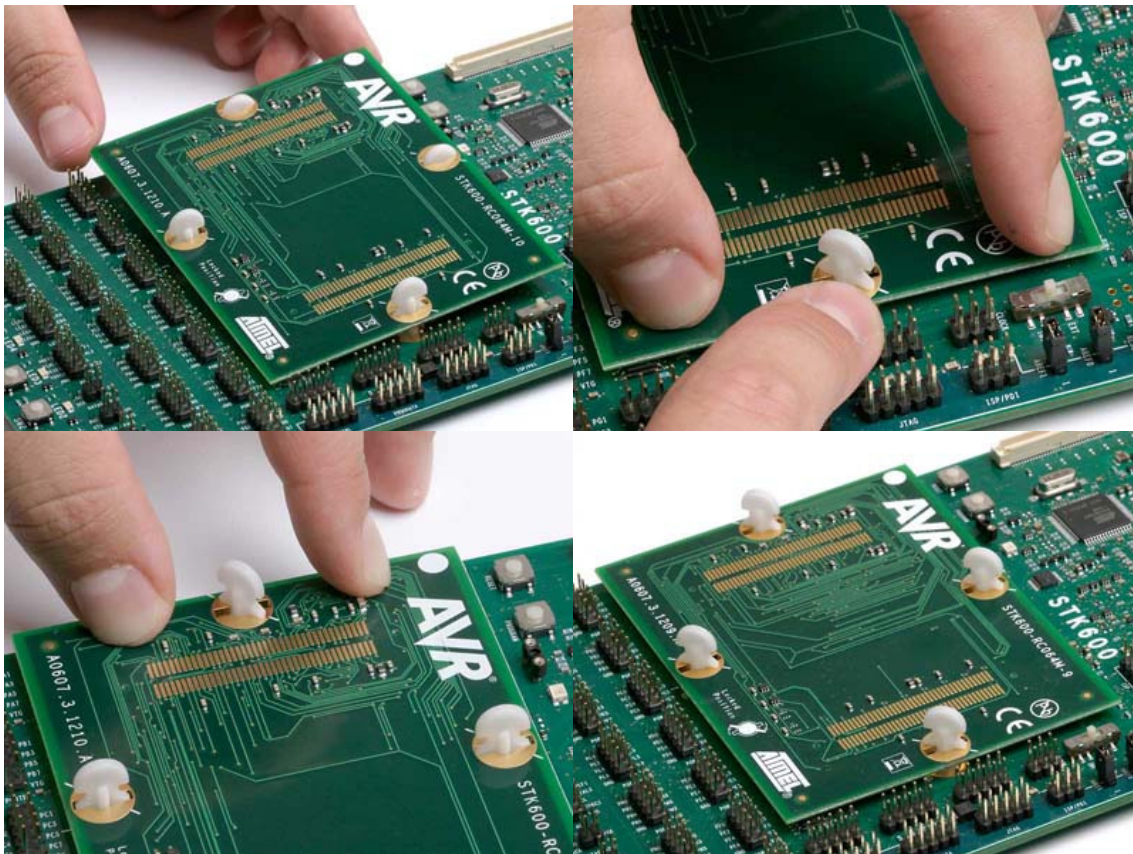

Socket card

Connecting the socket card is done in the same way as the routing card. Make sure that the clips align with the white line outside the clip holes on the routing card, then mount the socket card. The white spot on the socket card should align with the one on the routing card. Press down the socket

card (i.e. compress the spring loaded connector on the socket card) and turn the clip 45 degrees in the clockwise direction until it aligns with the white line outside the clip hole. It is easiest to do two opposite clips before locking the two last.

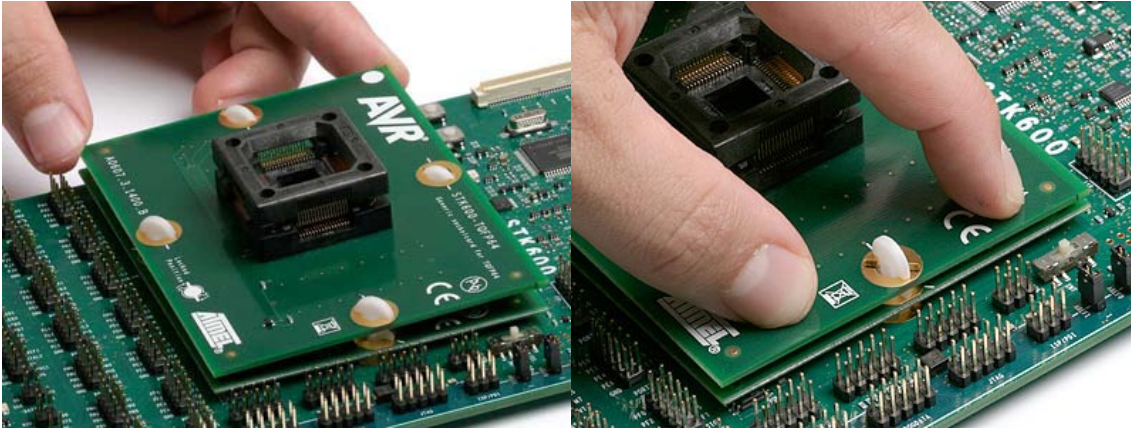

Note

Always rotate the clips within the 45 degrees window. Do not turn them around, that could cause the routing card below to un-hock from the clip.

3.4.2 Using screws and nuts

Motherboard

Insert the nuts into the STK600 motherboard from the bottom side. When properly installed the two locking springs should hold the nut in place.

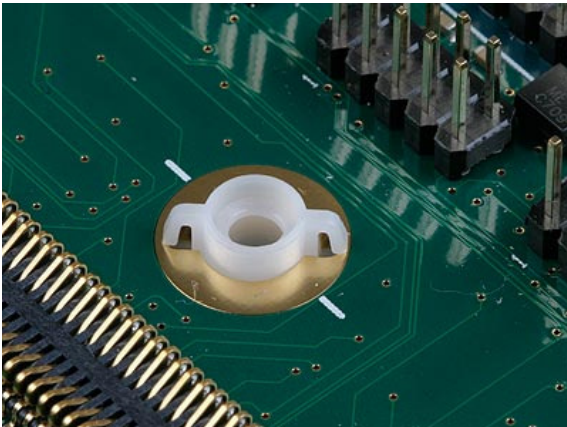

Routing and socket card

Place the routing card above the mother board, make sure that the whit spot in the corner matches the white spot on the motherboard. The small plastic taps on the ends of the spring loaded connectors should mate with the holes in the routing card. When the routing card is in the correct position, place the socket card onto the routing card with the white spot matching the one on the routing card. Make sure that the plastic taps on the connectors on the socket card mates with the routing card as well.

Insert the four screws, and tighten them firmly into the nuts.



3.5 Signal integrity

STK600 is designed to support a wide range of devices with different packages and pinouts. Many compromises has been taken to make this possible with one motherboard. The signal integrity is not optimised due to this. STK600 is not a reference design in any way, but a kit that serves as socket programmer with some additional peripheral hardware to get started with the AVR. Serial communication at the highest frequencies may not work.

4. Hardware Description

4.1 STK600 Block Diagram

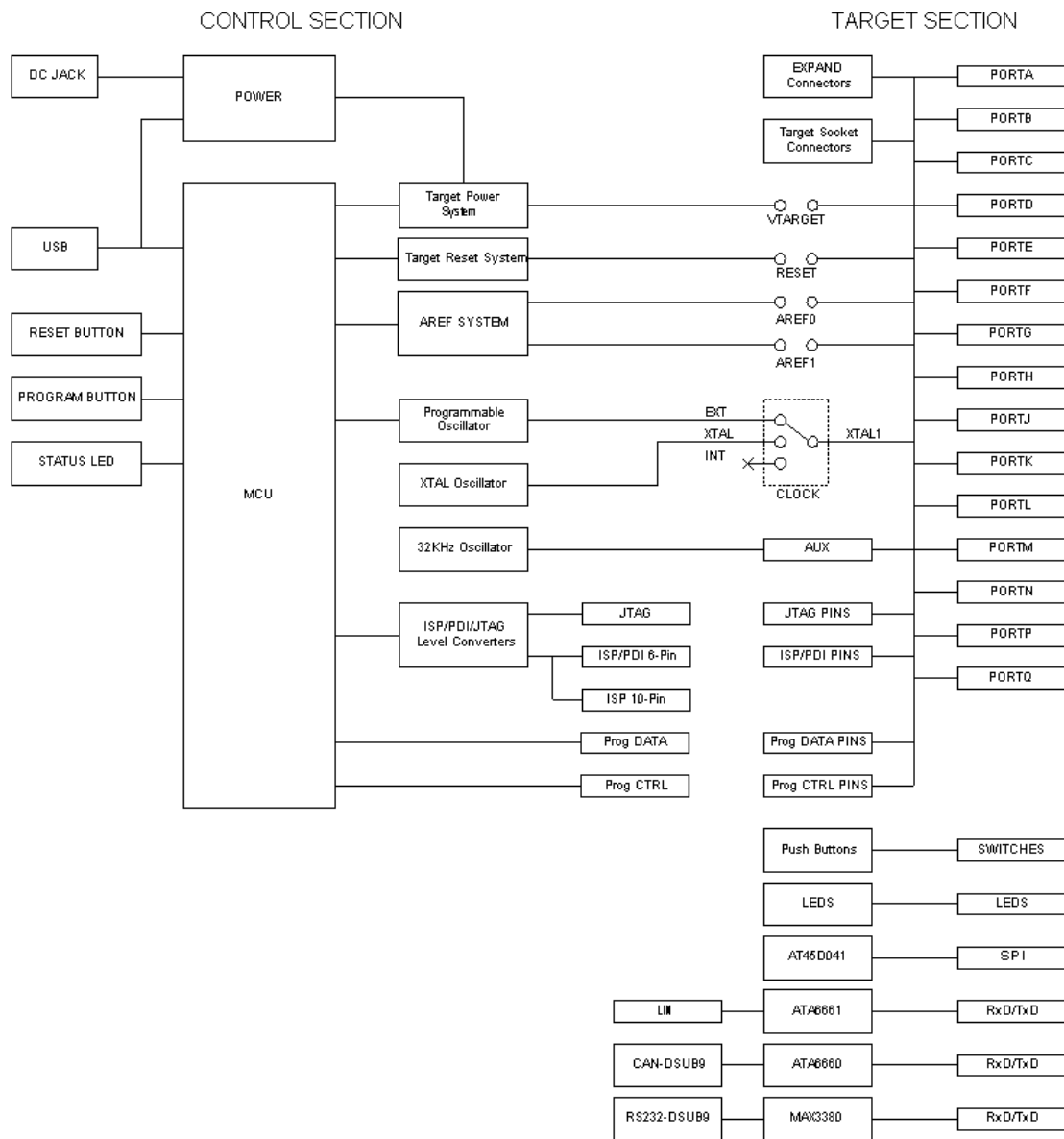

4.2 Target Voltage VTG

The VTG voltage is the supply voltage to the target AVR microcontroller. It is connected to the AVR's VCC pin. VTG can either be generated by STK600, or it can be supplied from an external source.



4.2.1 On-board VTG source

The on-board VTG source is set from AVR Studio. To use this source, the VTARGET jumper must be mounted. The on-board supply can be adjusted from 0.9 to 5.5V in steps of 0.1V.

VTG can also be set to 0V, but due to hardware limitations, onboard generated VTG can not be set between 0 and 0.9V.

Note: Always check the AVR datasheet for operating voltage range before adjusting VTG.

Powering STK600 from USB

When STK600 is powered through the USB cable approximately 300 mA can be delivered to the target section.

Powering STK600 from an external DC source

If an external DC jack input is used approximately 1A can be delivered to the target section.

4.2.2 External VTG

If the VTARGET jumper is removed, VTG must be supplied from an external source. Connect the external source to one of the VTG pins on any of the PORT headers. Always connect common ground (GND) when using an external VTG voltage.

When using an external source, the user must ensure that VTG is larger than any of the AREF voltages.

Note: The kit must always be powered when using an external VTARGET supply. If VTG voltage is supplied from an external source while the main power switch is in the off position the kit may become damaged.

4.2.3 Status LEDs

VTARGET LED

A green LED next to the VTARGET jumper will be lit when there is a voltage of 0.9V or higher available on the VTG net.

STK600 Status LED

If a short circuit is detected when using the on-board VTG supply, the STK600 status LED will blink red.

4.3 Analog Reference Voltages

The AVR's A/D converter needs a reference voltage to set its converting range. STK600 can supply two of these voltages, AREF0 and AREF1.

For all tinyAVR and megaAVR devices, only the AREF0 is connected through the routing card, whilst for xmegaAVR devices, AREF0 is connected to ArefA and AREF1 is connected to ArefB.

For xmega devices the AREF pins is also general purpose I/O pins. Hence, to use the pins as GPIO the Aref jumpers must be removed.

Note: For routingcard "STK600-RC100X-13" revision A and revision B the AREF1 is connected to PA1. These cards are marked "A0607.3.1213.A" and "A0607.3.1213.B"

If the AREF0/AREF1 jumpers are mounted, the on-board Analog Reference Voltage sources are connected to the target AVR's AREF pins. The On-board Analog Reference Voltages can be adjusted from the PC software in the range 0 to 5.5V, but not above VTARGET. The resolution and accuracy is 10mV.

The AREF0 and AREF1 generated voltages can also be connected to the analog comparator.

The target AVR's AREF signals are accessible on the AUX header. The figure below shows the connection of the AREF signals, the target section and the AREF sources.

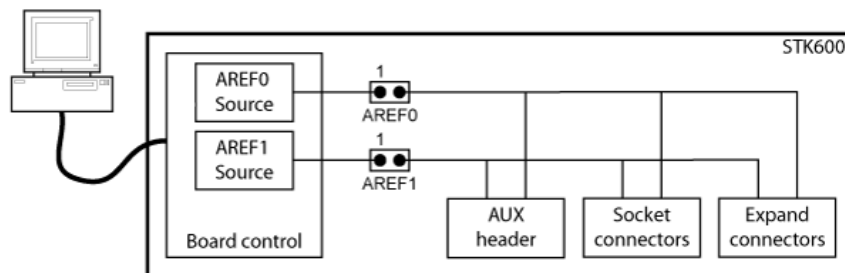

4.3.1 Using external voltage reference

AREF0	1	2	AREF1
XTAL1	●	●	XTAL2
RESET	●	●	32kHz
TOSC2	●	●	TOSC1
GND	●	●	VTG
AUX			

When the AREF0/AREF1 jumper is disconnected, ADC reference voltage can be supplied from an external source, by connecting to the AREF0/AREF pins on the AUX header.

When using external an source for AREF, the user must control that VTARGET is at a higher voltage level than AREF. This can be controlled easily by reading the VTG value from AVR Studio before setting AREF.

NOTE: The AREF0 and AREF1 voltage which are visible in the PC software are the STK600 generated voltages. Externally applied AREF voltages cannot be read from AVRStudio.

4.3.2 Using the internal voltage reference

If the AVR's internal voltage reference is used, the AREF0/AREF1 jumper must be removed.

4.3.3 Using Aref as analog input

AREF0 and AREF1 can also be used as analog inputs to any of the ADC channels.

For tiny and mega devices, where only AREF0 is connected to the device via the routing card, AREF1 can be connected to a ADC channel by connecting a cable from AREF1 on the AUX header and to the port pin header corresponding to the adc channel. (check the device datasheet for which port pin header to connect to).

If the AVR's internal voltage reference, or an external voltage reference is used, the AREF0/AREF1 jumper must be removed. If this is the case, AREF0 or AREF1 can be used as analog inputs by connecting a cable from pin 1 on the AREF0/AREF1 header to the port pin header corresponding to the adc channel.

4.3.4 AREF decoupling capacitor

The routing card has a decoupling capacitor on AREF. This is marked with silkprint on the PCB. For some AVR devices the AREF pin is on a pin which also is part of the high-voltage programming interface. On these routing cards the aref capacitor is not mounted, as it would make it impossible to use the high-voltage programming interface. A capacitor can be soldered to achieve better noise performance. A typical value is 10nF. The footprint for the capacitor is SMD size 0603.

4.3.5 Short circuit protection

The internal AREF voltage generators have a short circuit protection. If the STK600 measures the AREF0/AREF1 to be 0.3V or more below the setpoint, AREF will be shut off. When this happens, the status LED will blink red. The AREF0 and AREF1 will also be shut down by the Master MCU if a short circuit is detected on VTarget (in addition to shutting down VTarget). In this case, the status LED will blink red.

4.4 RESET Control

The STK600 controls the RESET signal to the target AVR. Under normal operation, the RESET line is held in an inactive, high state (pull-up to VTG).

4.4.1 The RESET jumper

The RESET jumper connects the RESET pin on the target AVR to the STK600. When the RESET jumper is mounted, STK600 controls the RESET signal. When the RESET jumper is not mounted, the RESET signal is disconnected. This latter is useful for prototyping applications with an external reset system.

The RESET jumper must always be mounted when High-Voltage programming an AVR device. If using an external reset system, it must allow the reset line to be controlled by the STK600 during programming.

4.4.2 The RESET button

STK600 has a reset button that resets the target AVR when being pushed. The button has no function if the RESET jumper is not mounted.

4.4.3 RESET signal on AUX header

The target AVR's RESET signal is accessible on the AUX header. This pin can be used to apply an external RESET signal. When applying an external reset signal, the reset jumper must be removed.

4.4.4 12V Programming Voltage

During High-Voltage Programming, STK600 applies 12V to the AVR's RESET line. Thus, an external reset circuit not capable of handling this must be disconnected before High-Voltage programming the AVR.

4.4.5 External RESET de-coupling

When connected to an external system, there is often an external pull-up resistor and a capacitor connected to the reset line. A typical reset connection is shown below.



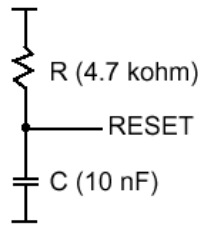

If the external pull-up resistor is too strong (i.e $\ll 4.7\text{k}\Omega$), STK600 may not be able to pull the RESET line low.

See also: [Reset Line](#) when programming an external target.

4.5 Port Connectors

All I/O port pins on the target AVR mounted on the STK600 are available on port pin connectors. These are labeled PORTA, PORTB, PORTC etc.

Depending to the AVR in use, different ports will be available.

The picture below shows PORTA. Here, all port pins PA0 to PA7 are available, in addition to the target voltage VTG and GND.

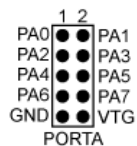

The other port connectors are identical, only with different signal names.

Cables can be mounted between the port connectors and the other peripherals on the board, or to external hardware.

4.5.1 AUX port connector

The AUX connector is located in the port connector area. The figure shows the pinout for the connector.

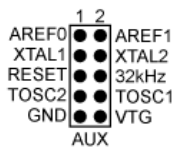

The following signals are available:

AREF0

Analog Reference voltage. This pin is connected to the AREF pin on devices having a single separate analog reference pin. For devices with two AREF pins, this pin is connected to the AREF+ pin. The AREF0 voltage is controlled from the PC software if the AREF0 jumper is mounted.

AREF1

Analog Reference voltage. This pin is connected to the AREF- pin on devices having two separate analog reference pin. The AREF1 voltage is controlled from the PC software if the AREF1 jumper is mounted.

XTAL1

The XTAL1 signal on the AVR is routed to this pin. If the CLOCK switch is set to the INT position, this pin can be used to apply an external clock signal.

XTAL2

The AVR's XTAL2 pin. If the CLOCK switch is set to the INT position, this pin can be used for external crystal with the XTAL1 pin.

RESET

The RESET pin on the AVR is available on this pin.

32KHz

A 32kHz clock signal is available on this pin. It can be connected to a device's TOSC1 pin in order to implement a real-time clock. Place a jumper between the 32KHz pin and the neighboring TOSC1 pin.

TOSC2 and TOSC1

For AVRs with a timer that can be clocked from an external low-frequency crystal, these two pins are available. The TOSC1 pin can easily be connected to the AUX port's 32KHz pin (32kHz clock signal) by a jumper.

4.6 AVR32 Pin Mapping

The AVR32 pin mapping is described in the tables below.

4.6.1 STK600-RCuC3A100-28 (100-pin AT32UC3A devices)

Device Pin Name STK600 Signal Name

PA00	PA0
PA01	PA1
PA02	PA2
PA03	PA3
PA04	PA4
PA05	PA5
PA06	PA6
PA07	PA7
PA08	PB0
PA09	PB1
PA10	PB2
PA11	PB3, MISO
PA12	PB4, MOSI
PA13	PB5, SCK
PA14	PB6
PA15	PB7
PA16	PC0
PA17	PC1
PA18	PC2
PA19	PC3
PA20	PC4
PA21	PC5
PA22	PC6
PA23	PC7
PA24	PD0
PA25	PD1
PA26	PD2
PA27	PD3
PA28	PD4
PA29	PD5
PA31	PD7
PB00	PE0
PB01	PE1
PB02	PE2
PB03	PE3
PB04	PE4
PB05	PE5
PB06	PE6
PB07	PE7
PB08	PF0
PB09	PF1
PB10	PF2
PB11	PF3
PB12	PF4
PB13	PF5

PB14	PF6
PB15	PF7
PB16	PG0, USB_ID
PB17	PG1, UVCON
PB18	PG2
PB19	PG3
PB20	PG4
PB21	PG5
PB22	PG6
PB23	PG7
PB24	PH0
PB25	PH1
PB26	PH2
PB27	PH3
PB28	PH4
PB29	PH5
PB30	PH6
PB31	PH7
PC00	TOSC1
PC01	TOSC2
PC02	XTAL1
PC03	XTAL2
TDI	TDI
TDO	TDO
TMS	TMS
TCK	TCK
DP	DP
DN	DN
VBUS	VBUS
VDDIN	VTG
AREF0	AREF0
VDDANA	VTG

4.6.2 STK600-RCuC3B0-21 (64-pin AT32UC3B devices)

Device Pin Name STK600 Signal Name

PA3	PA3
PA4	PA4
PA5	PA5
PA6	PA6
PA7	PA7
PA8	PB0
PA9	PB1
PA10	PB2
PA11	PB3, TOSC1
PA12	PB4, TOSC2
PA13	PB5
PA14	PB6, MOSI
PA15	PB7, SCK
PA16	PC0
PA17	PC1
PA18	PC2, XTAL1
PA19	PC3, XTAL1
PA20	PC4
PA21	PC5
PA22	PC6
PA23	PC7
PA24	PD0
PA25	PD1, MISO

PA26	PD2, USB_ID
PA27	PD3, UVCON
PA28	PD4
PA29	PD5
PA30	PD6
PA31	PD7
PB0	PE0
PB1	PE1
PB2	PE2
PB3	PE3
PB4	PE4
PB5	PE5
PB6	PE6
PB7	PE7
PB8	PF0
PB9	PF1
PB10	PF2
PB11	PF3
RESET	RESET
TDI	TDI
TDO	TDO
TMS	TMS
TCK	TCK
DP	DP
DN	DN
VBUS	VBUS
VDDIN	VTG
AREF0	AREF0
VDDANA	VTG

4.6.3 STK600-RCu3B48-27 (48-pin AT32UC3B devices)

Device Pin Name STK600 Signal Name

PA3	PA3
PA4	PA4
PA5	PA5
PA6	PA6
PA7	PA7
PA8	PB0
PA9	PB1
PA10	PB2
PA11	PB3, TOSC1
PA12	PB4, TOSC2
PA13	PB5
PA14	PB6, MOSI
PA15	PB7, SCK
PA16	PC0
PA17	PC1
PA18	PC2, XTAL1
PA19	PC3, XTAL1
PA20	PC4
PA21	PC5
PA22	PC6
PA23	PC7
PA24	PD0
PA25	PD1, MISO
PA26	PD2, USB_ID
PA27	PD3, UVCON
RESET	RESET

TDI	TDI
TDO	TDO
TMS	TMS
TCK	TCK
DP	DP
DN	DN
VBUS	VBUS
VDDIN	VTG
AREF0	AREF0
VDDANA	VTG

4.6.4 STK600-uC3-144 (144-pin AT32UC3A devices)

	Device Pin Name	STK600 Signal Name
	PA0	PA0
	PA1	PA1
	PA2	PA2
	PA3	PA3
	PA4	PA4
	PA5	PA5
	PA6	PA6
	PA7	PA7
	PA8	PB0
	PA9	PB1
	PA10	PB2
	PA11	PB3, MISO
	PA12	PB4, MOSI
	PA13	PB5, SCK
	PA14	PB6
	PA15	PB7
	PA16	PC0
	PA17	PC1
	PA18	PC2
	PA19	PC3
	PA20	PC4
	PA21	PC5
	PA22	PC6
	PA23	PC7
	PA24	PD0
	PA25	PD1, PP0
	PA26	PD2, PL4
	PA27	PD3, PL5
	PA28	PD4, PL6
	PA29	PD5, PP2
	PA30	PD6
	PB0	PE0
	PB1	PE1
	PB2	PE2
	PB3	PE3
	PB4	PE4, PP3
	PB5	PE5
	PB6	PE6
	PB7	PE7
	PB8	PF0
	PB9	PF1
	PB10	PF2
	PB11	PF3
	PB12	PF4
	PB13	PF5

PB14	PF6
PB15	PF7
PB16	PG0, USB_ID
PB17	PG1, PL7, UVCON
PB18	PG2
PB19	PG3
PB20	PG4
PB21	PG5
PB22	PG6
PB23	PG7
PB24	PH0
PB25	PH1
PB26	PH2
PB27	PH3
PB28	PH4
PB29	PH5
PB30	PH6
PB31	PH7, PP6
PX0	PJ0
PX1	PJ1
PX2	PJ2
PX3	PJ3
PX4	PJ4
PX5	PJ5
PX6	PJ6
PX7	PJ7
PX8	PK0
PX9	PK1
PX10	PK2
PX11	PK3
PX12	PK4
PX13	PK5
PX14	PK6
PX15	PK7
PX16	PL0
PX17	PL1
PX18	PL2
PX19	PL3
PX20	PM0
PX21	PM1
PX22	PM2
PX23	PM3
PX24	PM4
PX25	PM5
PX26	PM6
PX27	PM7
PX28	PN0
PX29	PN1
PX30	PN2
PX31	PN3
PX32	PN4
PX33	PN5
PX34	PN6
PX35	PN7
PX36	PP1
PX37	PP4
PX38	PP5
PX39	PP7
XIN0	XTAL1

XOUT0	XTAL2
XIN1	crystal socket
XOUT1	crystal socket
TOSC1	TOSC1
TOSC2	TOSC2
RESET	RESET
AREF0	AREF0
TDI	TDI
TDO	TDO
TMS	TMS
TCK	TCK
DP	DP
DN	DN
VBUS	VBUS
VDDANA	VTG
VCCIN, VBOOST, VCC0, VCC2, VCC3, VCC5, VCC6, VCC7	VTG

4.7 LEDs and Switches

STK600 has eight LEDs and eight switches that can be connected to I/O pins on the AVR. The LEDS and SWITCHES connectors are found in the port connector area.

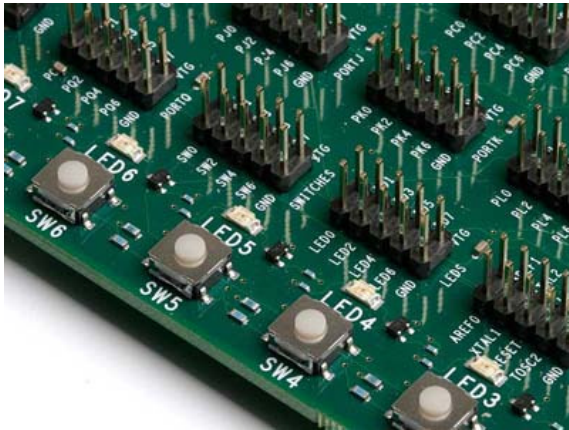

4.7.1 LEDs

The LEDs are labeled LED0 to LED7. The corresponding pins on the LEDS header have the same labels.

The LED hardware is shown in the figure below. The transistor circuit ensures the LED brightness is independent of target voltage.

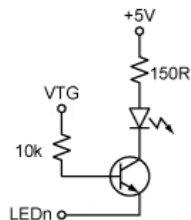

To light one of the LEDs, the corresponding pin found on the LEDS header must be pulled to GND.

To control the LEDs from the AVR, connect a cable between the LEDS header and one of the PORT headers. Use a 10-wire cable to connect to all eight LEDs or a two-wire cable to control one or two LEDs.

Just like the PORT headers, the LEDS header has GND and VTG on pin 9 and 10. When using a 10-wire cable, make sure the pin one indication on the cable (red wire, triangular arrow pointing on pin one) aligns to pin 1 on both the LEDS header and PORT pin header.

The I/O port connected to LEDn will not source any significant current when LEDn is driven high, but it will sink a current of approximately 18mA when LEDn is pulled to GND.

4.7.2 Switches

The switches are labeled SW0 to SW7, and are available on the SWITCHES header. The switch hardware is shown below:

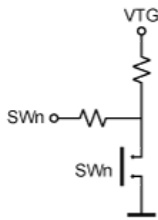

When pressing one of the switches, the corresponding SW pin on the SWITCHES header will be pulled low. When the switch is released, the switch's 10k pull-up will pull the line to VTG. The 150 Ohm resistor prevents a large current to flow to ground in case of wrong wiring.

Connect a cable between the SWITCHES header and one of the PORT headers. Use a 10-wire cable to connect to all eight switches or a two-wire cable to connect to one or two switches.

Note: On most AVR pins configured as input, you can enable an internal pull-up, removing the need for an external pull-up on the push button. In the STK600 design, an external 10K pull-up is present to give all users a logical '1' on SWn when the push button is not pressed, even if the internal pull-up is not enabled.

4.8 Clock Settings

STK600 includes several clock options for the target AVR.

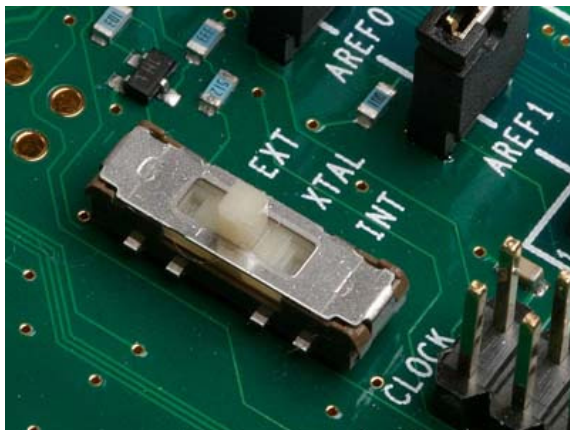

A switch selects between the following three options:

- Programmable clock generator
- Crystal oscillator (with socket for a crystal)
- XTAL1 Pin tri-stated (to be used with the AVR's internal RC oscillator)

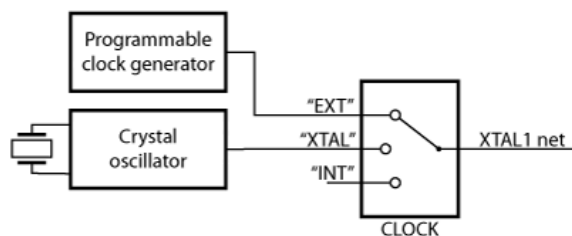

4.8.1 Programmable Clock Generator

The programmable clock generator is set from the PC software. The frequency can be set from 1.1kHz to 32MHz with 0.5% accuracy.

To use the programmable clock generator as clock source, set the CLOCK switch to EXT position.

4.8.2 Crystal Oscillator

The on-board crystal oscillator will work with ceramic resonators or crystals between 4 and 24MHz (AT-cut, fundamental, and parallel resonant crystals). Place a crystal in the crystal socket (located next to the PROGRAM button).

To use the crystal oscillator as a clock source, set the CLOCK switch to the XTAL position.

4.8.3 XTAL1 Pin Tri-stated

If the target AVR run on the internal oscillator, the XTAL1 pin can be disconnected from the clock sources on STK600.

To disconnect the XTAL1 pin, set the CLOCK switch to the INT position.

4.8.4 Real Time Clock

The STK600 also features a 32768 Hz oscillator, which can be used to make a real time clock. The output from the oscillator is available on the 32KHz pin on the AUX header. This clock can be routed to the TOSC1 pin on the target AVR by placing a jumper between the 32KHz and TOSC1 pin on the AUX header.

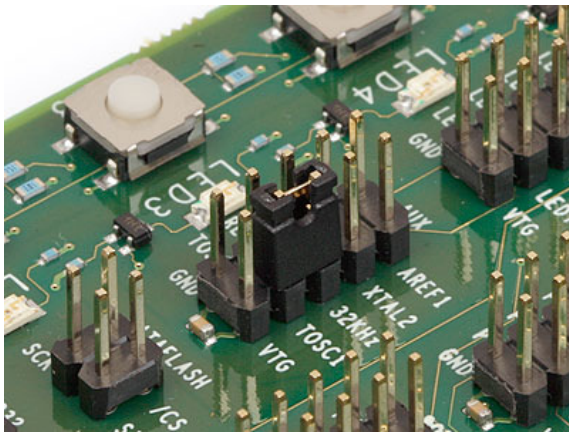

See also [Port Connectors](#) for more information about the AUX header.

4.8.5 Other Considerations

High-Voltage Programming

When programming the target AVR in High-Voltage programming mode, the clock settings is overridden and the device is clocked directly from the STK600 controller. The clock selection switch can be set to any position.

On-chip Crystal Oscillator

In a real-life application where the crystal can be placed close to the AVR's XTAL1 and XTAL2 pins, there is no need for an external oscillator circuit. The long clock signal lines and socket system connectors on STK600 makes it difficult to drive a crystal with the on-chip oscillators. This is resolved by having a crystal oscillator on STK600. The oscillator is designed to operate over the full target voltage range.

Shared XTAL1/Port Pin

Some AVR devices have a XTAL1 pin which also can be used as a regular I/O port pin. The routing card for these devices will connect the device pin to both the XTAL1 net and a port pin header on the STK600. Hence, to use the pin as a I/O port the clock selection switch must be set to position INT to disconnect the clock drivers on STK600 from the pin.

4.9 User RS232 Interface

The STK600 includes a RS232 hardware that can be used for communication between the target AVR microcontroller in the socket and a PC serial port. STK600 has a 9-pin DSUB connector that can be connected to a PC with a straight serial cable (not a null modem cable).

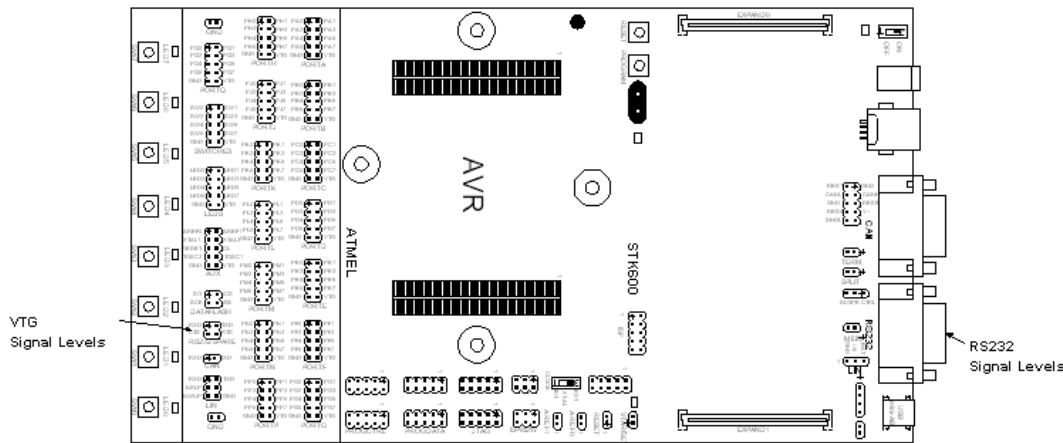

To use the RS232 interface, the AVR's UART pins must be connected to the appropriate pins on the "RS232 SPARE" pin header. Use a 2-wire cable to connect the AVR's RXD and TXD pins to the pin header. The "RS232 SPARE" pin header is found in the target header section, while the DSUB marked "RS232" is located on the other end of the card.

Optionally one can connect the RTS (Request To Send) and CTS (Clear To Send) signals to two free I/O ports. The RTS and CTS signals are used for flow control. The connection is shown below.

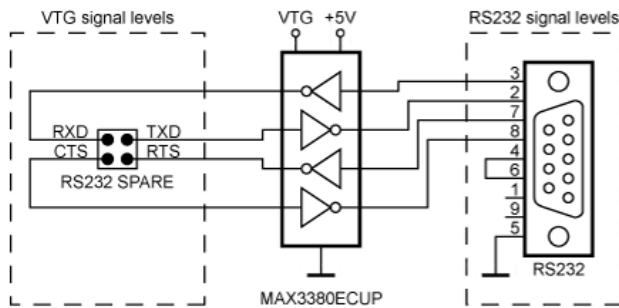

If the RTS and CTS lines are not controlled by the AVR, a jumper shorting the RTS and CTS pins on the "RS232 SPARE" header can resolve communication problems, if the PC side expects these handshake lines to be active.

4.9.1 Flow control and RTS/CTS signaling

Flow control is used to avoid data loss in transmission when one party is unavailable to receive data. When a DTE (such as a PC) wants to stop the data flow into it, it negates RTS. (read a negated "Request To Send" as "request NOT to send to me" (stop sending)). When the PC is ready for more bytes it asserts RTS and the flow of bytes to it can resume. Flow control signals are always sent in a direction opposite to the flow of bytes that is being controlled. DCE equipment (I.E. AVR) works the same way but sends the stop signal out the CTS pin (negated CTS: "(you are) NOT Cleared To Send").

4.10 DataFlash Non-Volatile Memory

An AT45DB041B 4Mbit DataFlash is included on the STK600 for non-volatile data storage. This is a high-density flash memory chip with SPI serial interface. Detailed datasheet of the DataFlash can be obtained from the Atmel CD-ROM or from the Atmel web site.

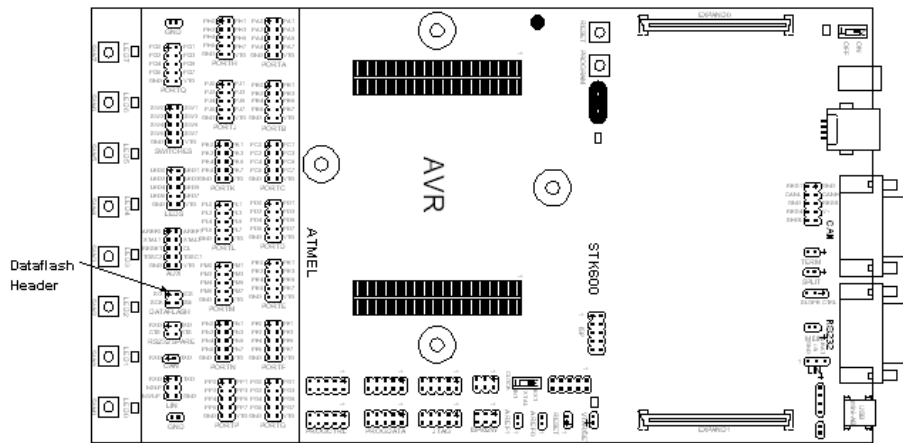

The dataflash can be connected to the I/O pins of the microcontroller sockets. The 4-pin header marked "DATAFLASH" can be used for connecting the SPI interface of the dataflash to the I/O pins on the target AVR microcontroller in the socket. 2-wire cables are included with STK600 for connecting the dataflash to the I/O pins. The connection of the I/O pins is shown on the picture below.

The block schematic of the dataflash connection is shown below, for connection of the dataflash to the AVR hardware SPI interface.

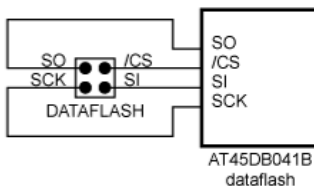

More information about how to use the DataFlash can be found on www.atmel.com.

4.11 Expansion Connectors

STK600 has two expansion connectors. All AVR I/O ports, programming signals, and control signals are routed to the expansion connectors. The expansion connectors allow easy prototyping of applications with STK600.

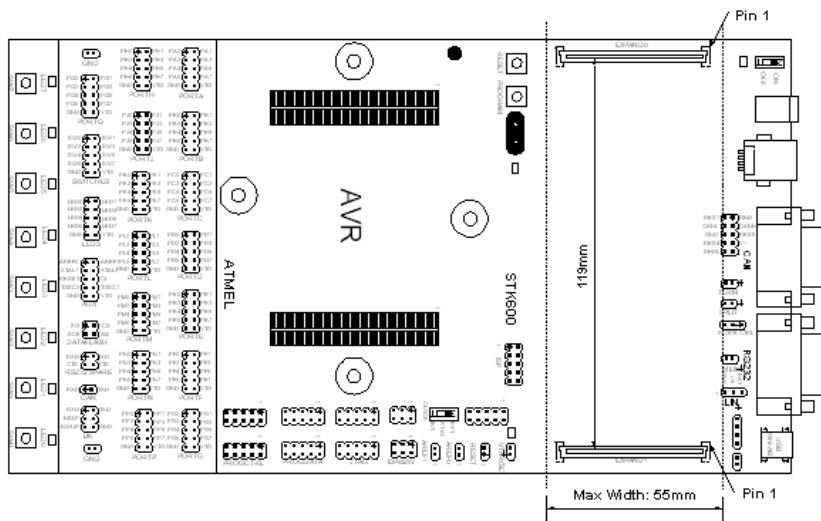

The connectors to be used on an expansion board is manufactured by FCI and has P/N: 61082-101402LF. See also www.fciconnect.com for more information.

The connectors must be placed with exactly 119mm between center to center. The expansion board must have a maximum width of 55mm to avoid collision with components on the mainboard.

The pinout of the expansion connectors is shown in the table below.

Table 4.1. EXPAND connector pinout

EXPAND0				EXPAND1			
GND	1	2	VTG	GND	1	2	VTG
PA0	3	4	PA1	PJ0	3	4	PJ1
PA2	5	6	PA3	PJ2	5	6	PJ3
PA4	7	8	PA5	PJ4	7	8	PJ5
PA6	9	10	PA7	PJ6	9	10	PJ7
GND	11	12	VTG	GND	11	12	VTG
PB0	13	14	PB1	PK0	13	14	PK1
PB2	15	16	PB3	PK2	15	16	PK3
PB4	17	18	PB5	PK4	17	18	PK5
PB6	19	20	PB7	PK6	19	20	PK7
GND	21	22	VTG	GND	21	22	VTG
PC0	23	24	PC1	PL0	23	24	PL1
PC2	25	26	PC3	PL2	25	26	PL3
PC4	27	28	PC5	PL4	27	28	PL5
PC6	29	30	PC7	PL6	29	30	PL7
GND	31	32	VTG	GND	31	32	VTG
PD0	33	34	PD1	PM0	33	34	PM1
PD2	35	36	PD3	PM2	35	36	PM3
PD4	37	38	PD5	PM4	37	38	PM5
PD6	39	40	PD7	PM6	39	40	PM7
GND	41	42	VTG	GND	41	42	VTG
PE0	43	44	PE1	PN0	43	44	PN1
PE2	45	46	PE3	PN2	45	46	PN3
PE4	47	48	PE5	PN4	47	48	PN5
PE6	49	50	PE7	PN6	49	50	PN7
GND	51	52	VTG	GND	51	52	VTG
PF0	53	54	PF1	PP0	53	54	PP1
PF2	55	56	PF3	PP2	55	56	PP3
PF4	57	58	PF5	PP4	57	58	PP5
PF6	59	60	PF7	PP6	59	60	PP7
GND	61	62	VTG	GND	61	62	VTG
PG0	63	64	PG1	PQ0	63	64	PQ1
PG2	65	66	PG3	PQ2	65	66	PQ3
PG4	67	68	PG5	PQ4	67	68	PQ5
PG6	69	70	PG7	PQ6	69	70	PQ7
GND	71	72	VTG	GND	71	72	VEXT
PH0	73	74	PH1	GND	73	74	VEXT
PH2	75	76	PH3	VCC	75	76	GND
PH4	77	78	PH5	VCC	77	78	GND
PH6	79	80	PH7	PDATA0	79	80	PDATA1
GND	81	82	VTG	PDATA2	81	82	PDATA3
XTAL1	83	84	AREF0	PDATA4	83	84	PDATA5
XTAL2	85	86	AREF1	PDATA6	85	86	PDATA7
GND	87	88	MOSI	PCTRL0	87	88	PCTRL1
TOSC1	89	90	MISO	PCTRL2	89	90	PCTRL3
TOSC2	91	92	SCK	PCTRL4	91	92	PCTRL5
TGT_RST	93	94	TDI	PCTRL6	93	94	PCTRL7
VCC6	95	96	TDO	GND	95	96	VCC3
GND	97	98	TMS	B_ID0	97	98	B_ID1
VCC6	99	100	TCK	B_ID6	99	100	B_ID7

4.12 User USB connector

STK600 has a USB connector that target AVR devices with USB interface can utilize. The connector is a mini-AB connector that supports On-the-go functionality. The routing card for the device connects the USB connector to the appropriate pins on the AVR.

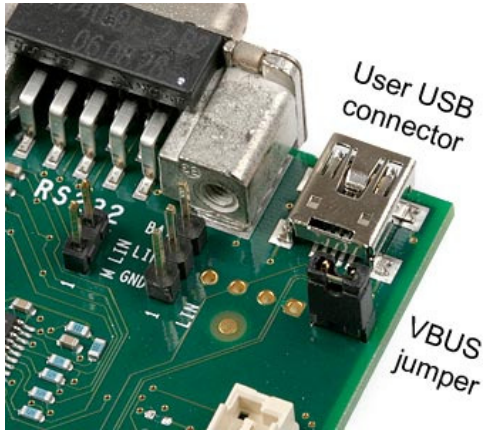

4.12.1 VBUS Generation

When the target AVR is acting as an On-the-go master it must supply VBUS voltage to the USB device it is controlling. To do so, place a jumper on the pin header (J901) next to the USB connector. The FET is controlled by the UVCON signal, also routed to the target AVR.

When not using the VBUS generation feature, the jumper must be removed.

Note: VCC is 5.3V

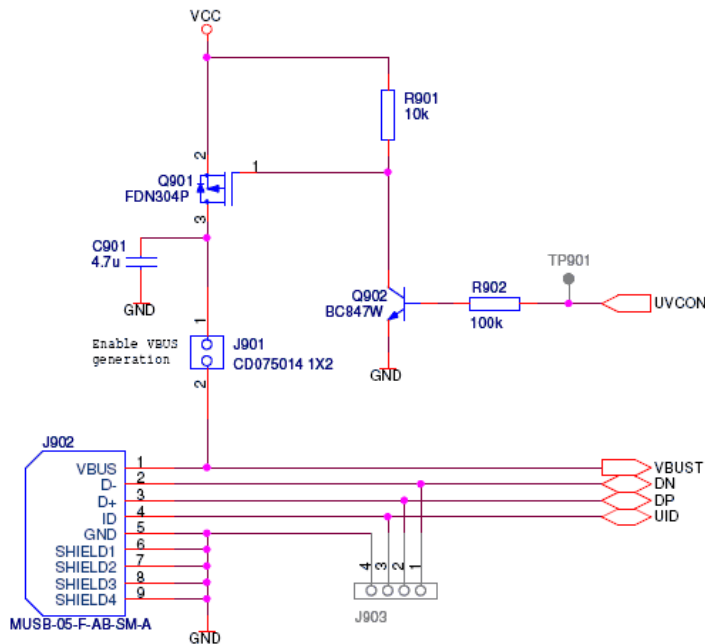

4.13 CAN transceiver

Controller Area Network (CAN) is a broadcast, differential serial bus standard typically used in the automotive industry. CAN features high immunity to electromechanical noise and arbitration free fixed priority.

STK600 features the ATA6660 CAN transceiver. A male DB9 connector and a 10 pin header is provided for bus connection

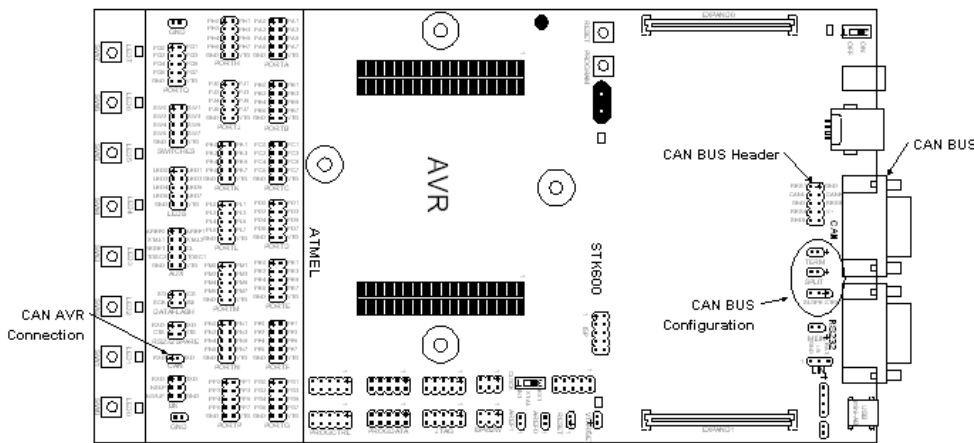

If a network termination is needed (CAN baudrate higher than 100 Kb/s), the 'TERM' jumper can be mounted to insert a 120 ohms resistor between CAN-H and CAN-L.

'SLOPE CTRL' is provided to adjust the CAN signal slopes and prevent unsymmetrical transients on the bus lines. The center pin on 'SLOPE CTRL' is connected to the ATA6660 RS pin. This must be held below 0.87-VTG which is the standby threshold voltage for AT6660.

Mount a jumper to either side of 'SLOPE CTRL' to prevent AT6660 from going to standby.

The CAN transceiver is connected to the MCU through the two-pin (rx and tx) 'CAN' header near the switches on STK600. The target MCU can be any AVR (bit banging or USART), but is more typically one of the AT90CAN series which support the CAN protocol in hardware.

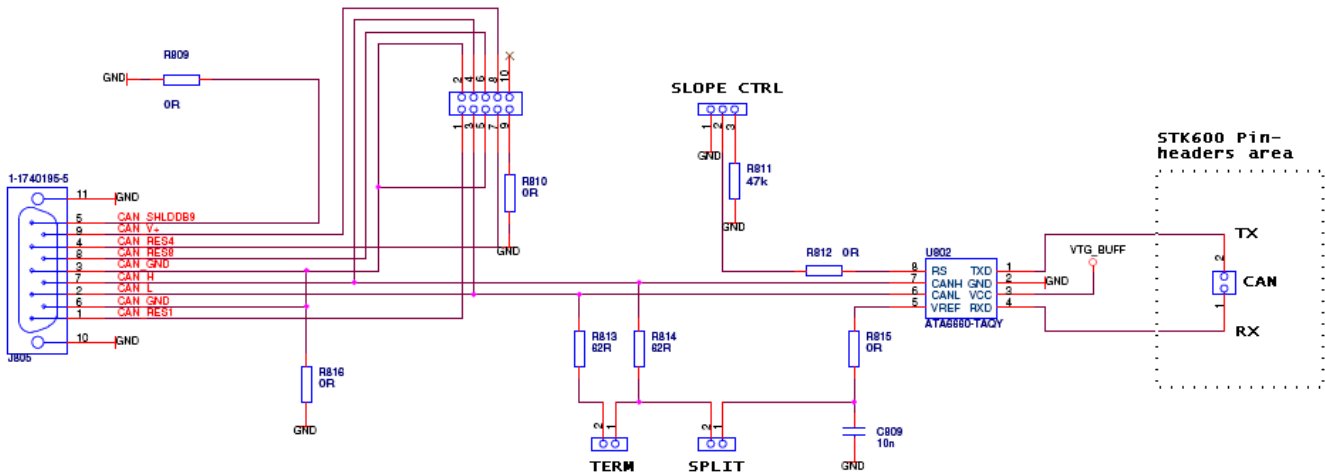

4.14 LIN transceiver

Local Interconnect Network (LIN) is a broadcast serial network comprising one master and many (up to 16) slaves. The LIN bus is typically used in the automotive industry as smaller and less expensive sub-network of a CAN bus to integrate intelligent sensor devices or actuators.

STK600 features the ATA6661 LIN transceiver. a three-pin header serves to connect to the bus. With the ATA6661 an AVR on the STK600 can implement a LIN master or a LIN slave.

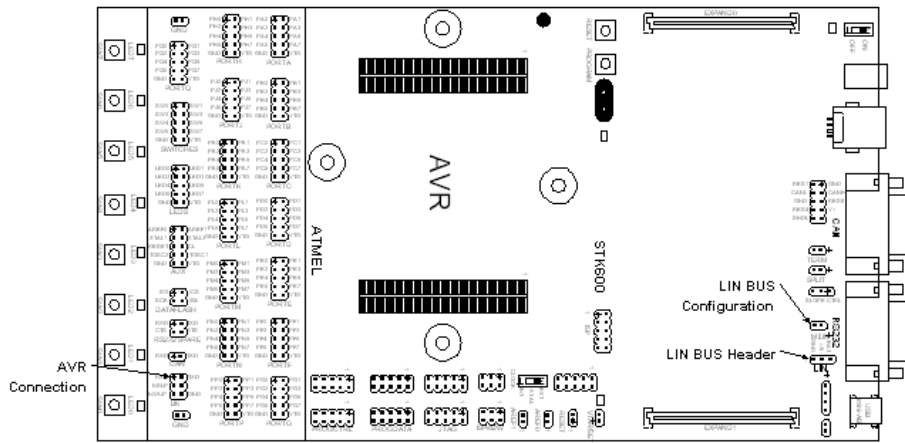

The 'M LIN' jumper provides the master node pull-up, required if the application running on STK600 is the LIN bus master.

The 3-pin LIN connector must provide V-battery ('BAT') 12V>BAT>5V, and GND. 'BAT' must be supplied from an external source. For further reference, see the ATA6661 datasheet.

The LIN transceiver is connected to the MCU through the six-pin 'LIN' header near the switches on STK600. The target MCU will usually implement the LIN protocol in software through a USART interface. The 'NSLP' pin must be actively driven high to keep the ATA6661 from sleep mode.

Note: Due to ATA6661 design, it is mandatory to enable the internal pull-up on PD2 (RxLIN) when LIN is used (c.f. AT90CAN128 Datasheet, section "I/O Ports").

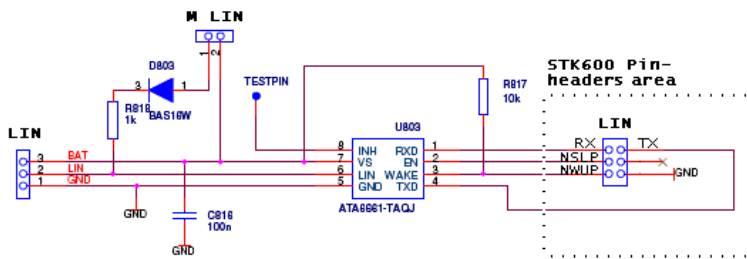

4.15 Miscellaneous

STK600 has two push buttons and three LEDs for special functions and status indication. The following section explains these features. The figure above shows the placement of these functions.

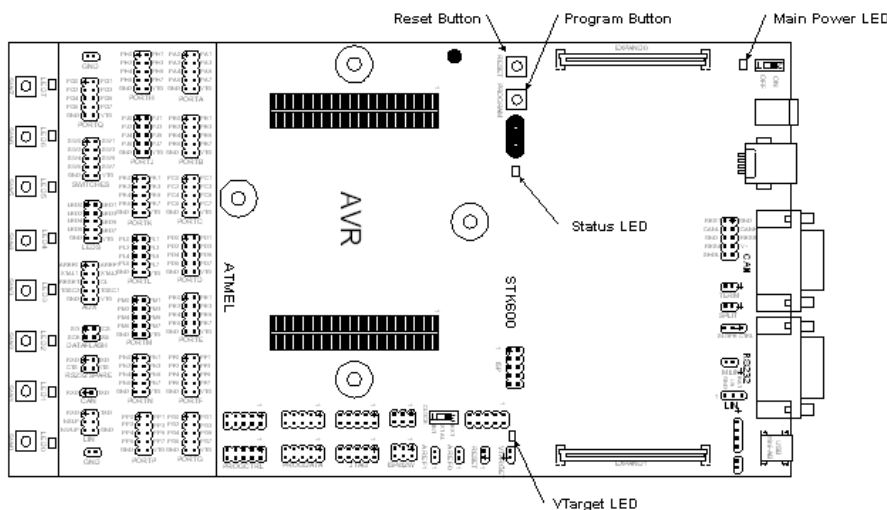

4.15.1 PROGRAM Push Button

Future versions of AVR Studio may upgrade the master MCU on STK600. AVR Studio will then detect old software versions of STK600 and update the Flash program memory of the master MCU. To do this the user is required to push the PROGRAM button when powering on STK600. AVR studio issues instructions on how to perform the upgrade during the upgrade process.

4.15.2 Main Power LED

The red power LED is directly connected to the STK600 main power supply. The power LED is always lit when power is applied to STK600.

4.15.3 Target Power LED

The target power LED is lit when voltage applied to the target AVR device is 0.9V or higher.

4.15.4 Status LED

- ORANGE: Busy programming
- ORANGE/RED Blinking: Upgrade mode
- RED: No board detected.
- GREEN: READY
- ORANGE Blinking: Wrong combination of routing and socket card.
- RED Blinking: VTarget or Aref short circuited.
- RED Blinking high frequency: To much current drawn from supply. If powered from USB, try to connect an external supply to DC jack.

During programming the LED has orange color. When the target AVR device is successfully programmed the LED will turn green

5. Programming

5.1 ISP Programming

In-System Programming uses the AVR internal SPI (Serial Peripheral Interface) to download code into the flash and EEPROM memory of the AVR. ISP programming requires only VCC , GND, RESET and 3 signal lines for programming. No high voltage signals are required. The ISP programmer can program both the internal flash and EEPROM, fuses, lockbits and calibration bytes.

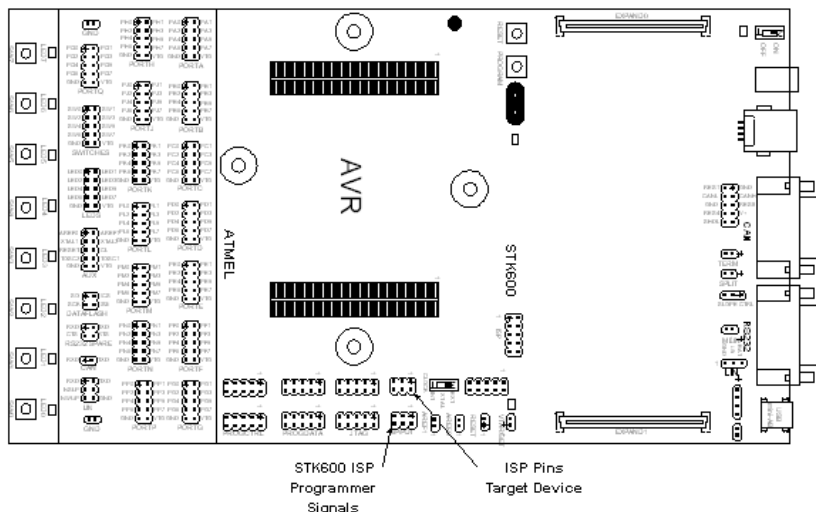

Note that the ISP frequency (SCK) must be less than 1/4 of the target clock. The ISP frequency is set by the STK600 programming dialog in AVR Studio.

Note that if ISP programming will NOT work if one or more of the following cases are true:

- SPIEN, SPI Enable fuse is un-programming
- RSTDISBL, Reset Disable fuse is programmed (for devices with this fuse)
- DWEN, DebugWIRE Enable fuse is programmed (for devices with this fuse)

Refer to the AVR datasheet for information about the fuses.

Use High-Voltage programming to re-enable the ISP interface from the situation listed above. Either HVPP or HVSP depending on what is supported by the AVR.

5.1.1 Hardware setup for On-board programming

1. Mount the routing and socket card and the target device. See the Socket System section on how to do this.
2. Connect a 6-wire cable between the two 6-pins ISP headers on the STK600. See picture below.
3. Ensure that the VTARGET jumper is mounted, and that the voltage is within the operating range for the target device.

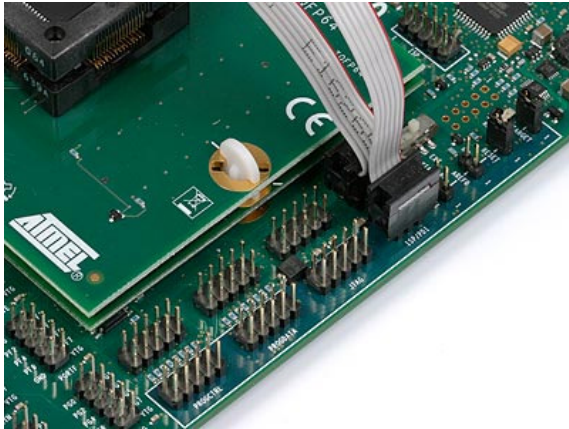

See the *Programming Dialog* pages in the AVR Studio help file for information on the STK600 programming dialog.

The pinout of the 6 and 10-pins ISP header is shown below:

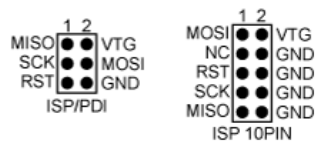

It is not necessary to remove the ISP cable while running a program in the AVR. The port pins used for ISP programming can be used for other purposes in your program.

See also: [In-System Programming of an External Target System](#)

5.1.2 AREF

The AREF0 jumper must be removed before programming of devices that have AREF on a pin used by the serial programming interface.

Devices that are affected by this uses these routing cards:

- STK600-RC008T-2

5.2 Parallel High Voltage Programming

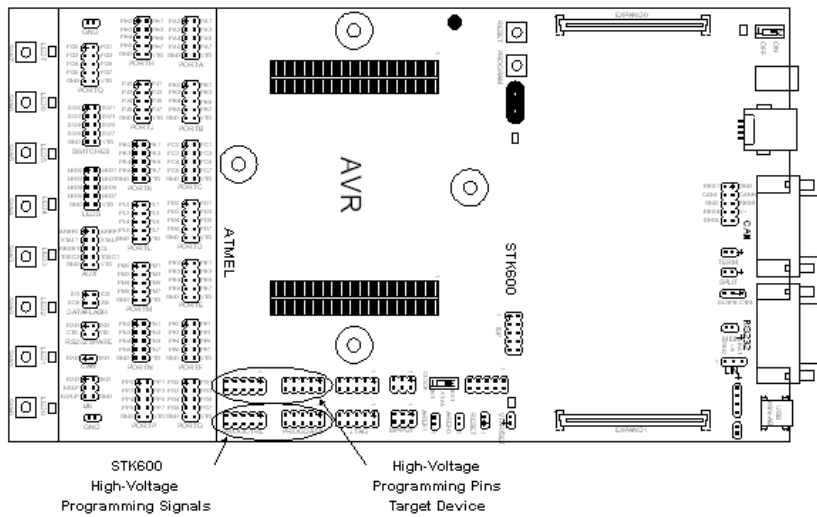

5.2.1 Hardware setup for On-board programming

Follow the steps below to do Parallel High Voltage Programming. Note that this interface is only intended for use on-board STK600.

1. Mount the routing and socket card and the target device. See the Socket System section on how to do this.
2. Use the two 10-wire cables supplied with the STK600 to connect the PROG DATA and the PROG CTRL to the target device, as shown in the picture below.
3. Mount both the VTARGET jumper and the RESET jumper
4. Ensure that VTarget is between 4.5V and 5.5V

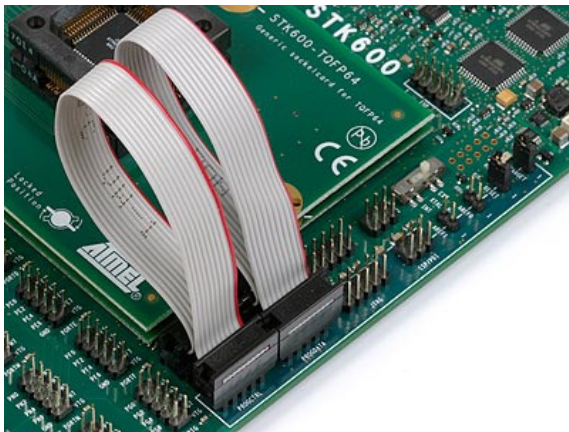

See the *Programming Dialog* pages in the AVR Studio help file for information on the STK600 programming dialog.

Note that the AREF jumper must be removed before programming of devices that have AREF on a pin used by the High Voltage programming interface.

Devices that are affected by this uses these routing cards:

- STK600-RC008T-7
- STK600-RC020T-8
- STK600-RC014T-12
- STK600-RC020T-23

5.3 Serial High Voltage Programming

The AVR's with low pin count have too few pins to use parallel communication during High-Voltage programming. They use serial communication

instead. This means that less signals have to be routed. Note that this interface is only intended for use on-board STK600.

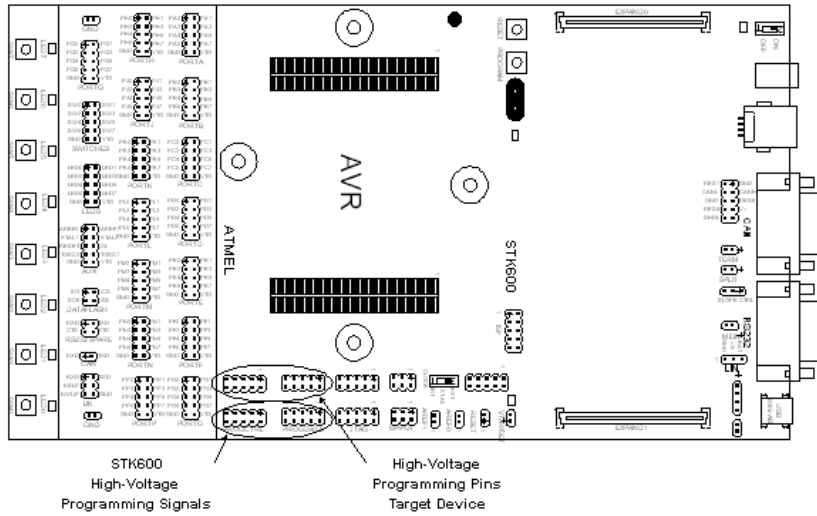

5.3.1 Hardware setup for On-board programming

1. Mount the routing and socket card and the target device. See the Socket System section on how to do this.
2. Use the a 10-wire cable supplied with the STK600 to connect the PROG DATA to the target device, shown in the picture below.
3. Note for ATtiny24/44/84 a cable on PROG CTRL is required as well, as for the Parallel High Voltage Programming.
4. Mount both the VTARGET jumper and the RESET jumper.
5. Ensure that VTarget is between 4.5V and 5.5V before programming.

See the *Programming Dialog* pages in the AVR Studio help file for information on the STK600 programming dialog.

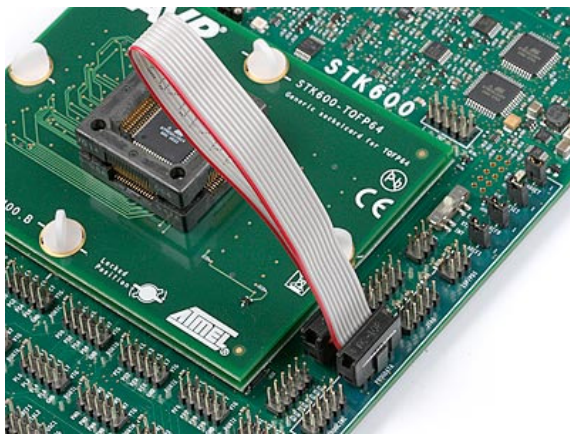

5.4 JTAG Programming

AVR devices with a JTAG port can be programmed through this interface.

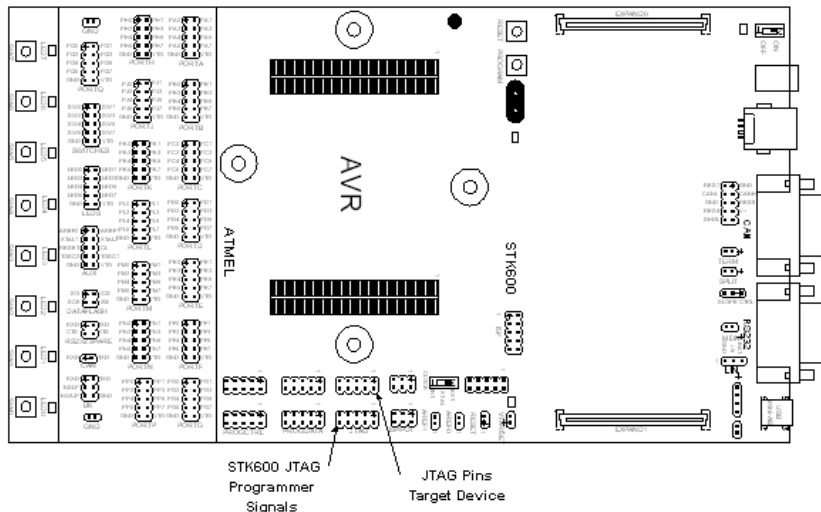

5.4.1 Hardware setup for On-board programming

1. Mount the routing and socket card and the target device. See the Socket System section on how to do this.
2. Connect a 10-wire cable between the two 10-pins JTAG headers on the STK600. See picture below.
3. Ensure that the VTARGET jumper is mounted, and that the voltage is within the operating range for the target device.

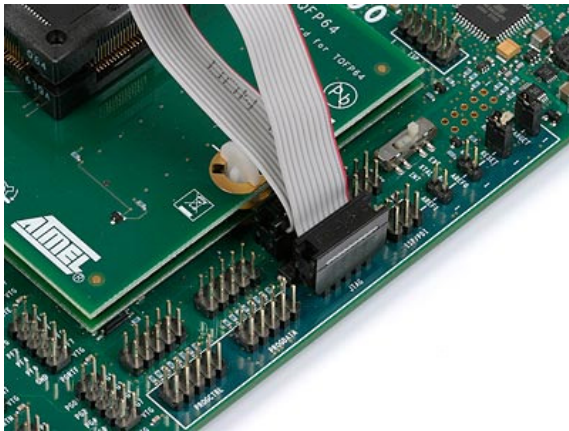

See the *Programming Dialog* pages in the AVR Studio help file or the AVR32 Studio help for information on how to program the device using JTAG.

The pinout of the JTAG header is shown below:

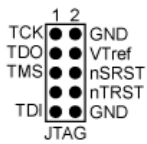

See also: [In-System Programming of an External Target System](#)

5.5 PDI Programming

All ATxmega devices have the new PDI programming and debugging interface. It can, in-system, download code into the flash application and boot memories, EEPROM memory, fuses, lockbits and signature information.

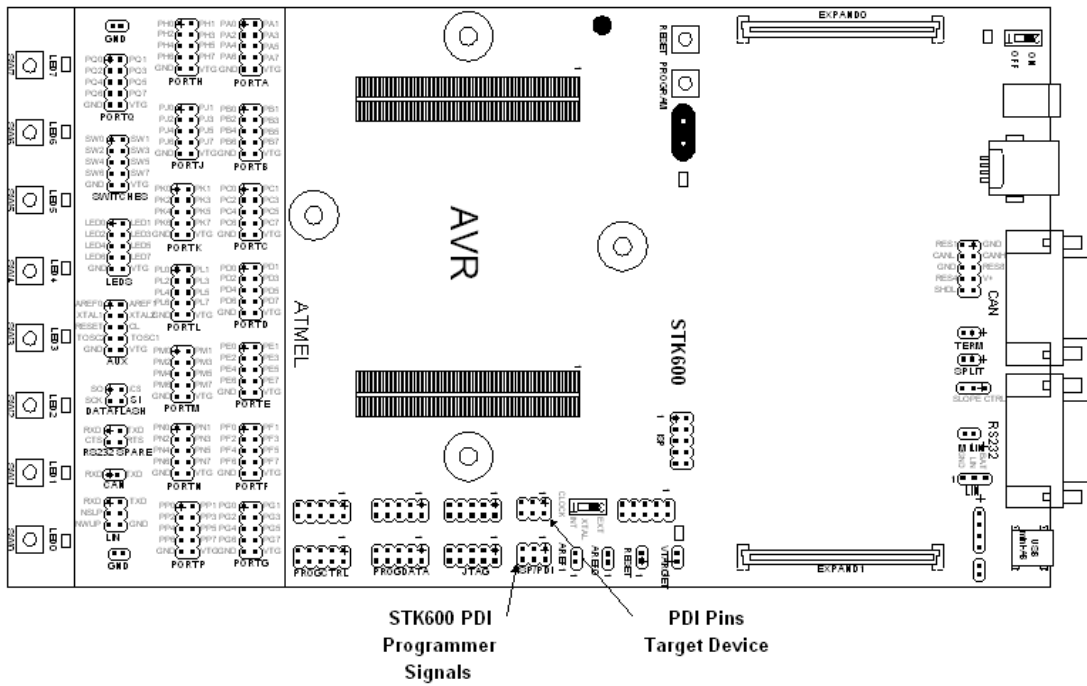

The PDI interface requires two of the device's pins, PDI_DATA and PDI_CLOCK. On STK600, they are found on the ISP/PDI connector.

5.5.1 Hardware setup for On-board programming

1. Mount the routing and socket card and the target device. See the Socket System section on how to do this.
2. Connect a 6-wire cable between the two 6-pins ISP/PDI headers on the STK600. See picture below.
3. Ensure that the VTARGET jumper is mounted, and that the voltage is within the operating range for the target device.

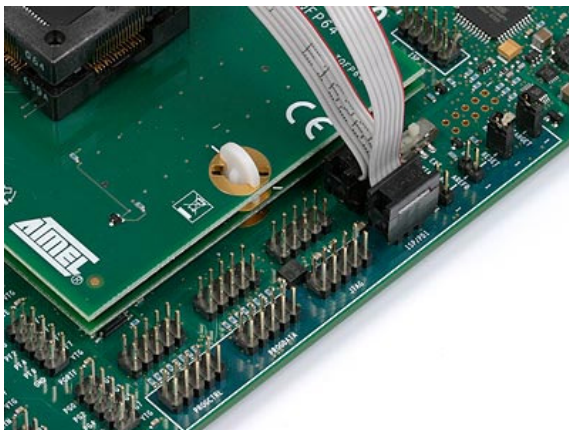

The pinout of the 6-pins ISP/PDI header when in PDI mode is shown below:

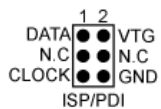

5.6 TPI Programming

The TPI (Tiny Programming Interface) found on some ATtiny devices can download code into the memories of these devices.

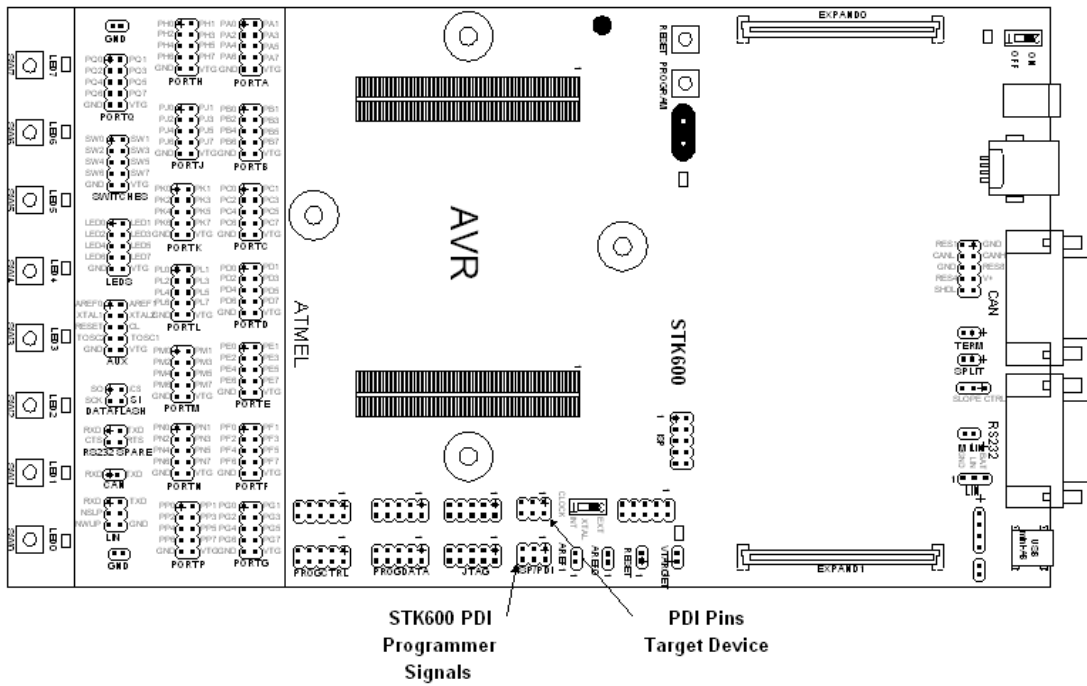

The TPI interface requires two of the device's pins, TPIDATA and TPICLK, in addition to the RESET pin. On STK600, they are found on the ISP/PDI connector. Note: TPI is only supported on-board, i.e it is not possible to program a device on an external board through the TPI interface.

5.6.1 Hardware setup for On-board programming

1. Mount the appropriate cards and the target device. See the Socket System section on how to do this.
2. Connect a 6-wire cable between the two 6-pins ISP/PDI headers on the STK600. See picture below.
3. Ensure that both the VTARGET and RESET jumpers are mounted, and that the voltage is the within the operating range for the target device.

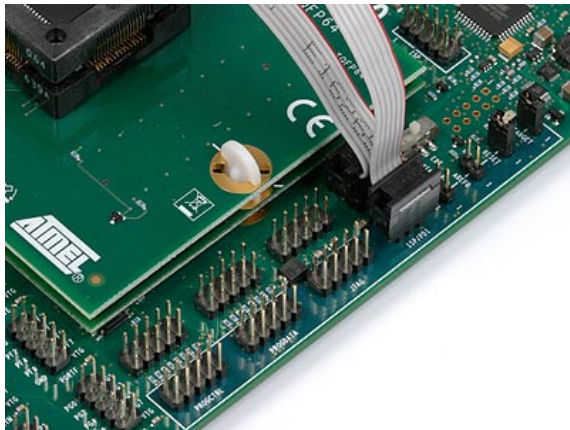

5.7 In-System Programming of an External Target System

The STK600 can be used as a programmer to program AVR devices in other applications. There are two different ISP connector pin-outs available, a 6-pin and a 10-pin version. Both are supported by STK600. The 6-pin header is a combined ISP and PDI connector. In addition STK600 can be used as a JTAG programmer for AVR devices with a JTAG interface.

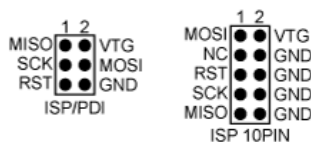

ISP connector pinouts

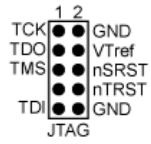

JTAG connector pinout

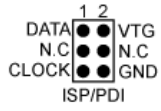

PDI connector pinout

Select the device to be programmed in the same way as programming a device on STK600. The VCC of the target application is detected by STK600 and signals are converted into voltage levels suitable for the target system.

Note: If the other application has its own power supply, the VTARGET jumper must be removed before connecting STK600 to the other application. STK600 may be damaged if the VTARGET jumper is not removed.

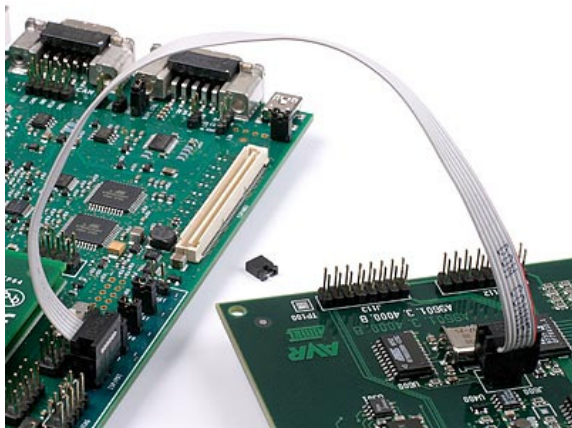

ISP or PDI programming an external target using the 6-pin connector

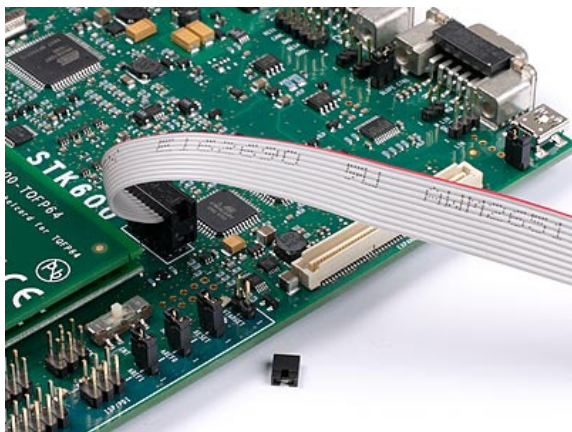

ISP programming an external target using the 10-pin connector

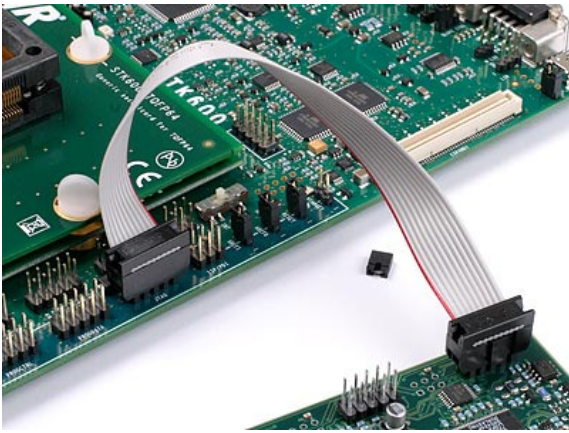

JTAG programming an external target

See the Programming Dialog pages in the AVR Studio help file for information on the STK600 programming dialog.

See also the [Target Voltage](#) section.

5.7.1 Reset Line

The Reset line on any target board connected to STK600 should have a pull-up resistor. This pull-up should not be stronger than 2.2k ohm (i.e. it should not be below 2.2kohm). If the pull-up resistor on the reset line is too strong, the short circuit protection will trigger when the reset is forced low by the STK600. Any de-coupling capacitor should not be larger than 10uF.

6. Troubleshooting and Support

6.1 Troubleshooting Guide

Table 6.1.

Problem	Reason	Solution
The main power LED is dark	The power switch is OFF	Turn on the power switch
	No power source is connected to STK600	Do one of the following: <ul style="list-style-type: none"> Connect a USB cable between STK600 and a PC. Make sure the PC is turned on. Connect a DC power cable to STK600. Note: The DC-jack must have a center pin with positive polarity.
The preprogrammed example code does not toggle the LEDs	There is no AVR device in the socket	Plug the AVR device into the right socket (see ISP Programming and Parallel High Voltage Programming).
	The LEDs are not connected to the I/O ports	Connect the LEDs header to the PORTD header, and SWITCHES header to PORTB header (see LEDs and Switches).
	No target voltage	Ensure that the VTG jumper is mounted and that VTG is set above 1.8V from AVRStudio
	The flash memory is erased	Reprogram the AVR device
The AVR device can not be programmed using SPI.	The AVR device is inserted with wrong orientation	Check that the notch on the AVR socket matches the notch on the AVR device.
	The ISP/PDI headers are not connected	Connect the 6-pin flexible cable between the two 6-pin ISP/PDI headers.
	The VTARGET voltage is too low	Check the AVR datasheet for minimum operating voltage
	The memory lock bits are programmed	Erase the memory before programming
	The SPI enable fuse is un-programmed	Program the SPIEN fuse using Parallel High Voltage Programming or Serial High Voltage Programming
	Reset disable fuse is set.	Check reset disable fuse.
	SPI frequency is too high.	Check STK600 SPI frequency and make sure it is lower than target clock divided by 4.
	CKDIV fuse is set	Reduce ISP programming speed

	External pullup resistor on reset line too low.	Ensure that external pullup resistor is $\geq 4.7k\Omega$.
	AREF0 jumper mounted	For some devices the AREF0 is connected to a pin used for the ISP interface. The AREF0 jumper must therefore be removed to do serial programming of these devices. See the ISP Programming section for which routingcards this applies.
The AVR device can not be programmed using JTAG.	The VTARGET voltage is too low	Check the AVR datasheet for minimum operating voltage
	The JTAG headers are not connected	Connect the 10-pin flexible cable between the two 10-pin JTAG headers. See JTAG Programming .
	The JTAG enable fuse is un-programmed	Program the JTAGEN fuse using Parallel High Voltage Programming or Serial High Voltage Programming
	The memory lock bits are programmed	Erase the memory before programming
The AVR device can not be programmed using high-voltage programming.	The VTARGET voltage is too low	Ensure that the voltage is at least 4.5V.
	The high-voltage programming headers are not connected	Mount cables between the programming headers. See Parallel High Voltage Programming or Serial High Voltage Programming
	The reset jumper is not mounted	Mount the reset jumper
	The I/O ports are connected to peripheral circuitry (leds, switches, etc.)	Remove all peripheral connections from the I/O ports belonging to the high-voltage programming interface.
	The memory lock bits are programmed	Erase the memory before programming
	AREF0 jumper mounted	For some devices the AREF0 is connected to a pin used for the parallel programming interface. The AREF0 jumper must therefore be removed to do parallel programming of these devices. See the Parallel High Voltage Programming section for which routingcards this applies.
AVR studio can not connect to STK600	USB cable is not connected, or power is off	Connect USB cable
	Firmware is in an hang-up state	Toggle power on STK600.
The status LED is blinking orange	Wrong combination of routing and socketcard, or card removed when the kits is powered.	Check the device support file for routing and socketcard combination. Always turn of kit power before removing or mounting routing and socketcards.
The status LED is blinking orange	The mounted cards is not recognized by STK600.	The routing and socketcard identification table in STK600 must be upgraded. Start AVRStudio and connect to kit using programming dialog. This will initiate a silent upgrade of the routing and socketcard table in the STK600 controller.
The status LED is blinking red with low frequency	Short circuit on VTarget or AREF	Resolve the short circuit.
The status LED is blinking red with high frequency	To much current drawn from supply	If the kit is powered from USB, try connecting a external power to the DC jack.
The LEDs don't work (running from external VTarget.)	STK600 must be powered for LEDs to work.	Supply power to STK600 and turn it on.

6.2 Technical Support

For technical support please contact avr@atmel.com. When requesting technical support for STK600 please include the following information:

- Version number of AVR Studio. This can be found in AVR studio menu "Help/About"
- PC processor type and speed
- PC operating system and version
- What target AVR device is used (Complete part number)
- Programming voltage
- Jumper settings
- A detailed description of the problem

6.3 Manual Firmware Upgrade

If an automatic firmware upgrade fails, or for some other reason connection to STK600 cannot be established, a manual firmware upgrade may resolve the problem.



Before starting this procedure, make sure the latest AVR Studio release is installed on the computer.

1. Turn off STK600 and connect it to the PC using the USB cable
2. Press and hold the PROGRAM button when turning on the STK600 power switch. The status LED will flash red and orange, indicating upgrade mode.
3. In AVR Studio, go to the Tools menu and select STK600 Upgrade
4. The Atmel STK600 Upgrade program will start. If connection is established, the Status will show "STK600 present"
5. Press the Start Upgrade button. The upgrade program will upgrade STK600's firmware.
6. When complete, a message box will show if the upgrade was successful or not. Cycle power on STK600.
7. If the upgrade was successful, the status led will now be green. Try to connect to the starter kit with the programming tool in AVR Studio.